

**NOTE: Always use plenty of cutting fluid when using the Cut-off Tool.**

**SHERLINE  
PRODUCTS**

INCORPORATED 1974

## Rear Mounted Cut-off Tool Holder

P/N 3018

After completing a part in the lathe it is frequently necessary to separate the part from the excess material used for chucking. This operation is best accomplished with the use of a cutoff tool or "parting tool" as it is sometimes called. The Sherline cut-off tool and holder consists of a very slender high speed tool steel cutting blade mounted in a special tool holder. The thinness of the blade (.040") enables it to feed into the part quite easily and at the same time minimizes the amount of waste material. The turning speed for parting should be approximately one-half the normal turning speed for any given material. One word of caution; **never use a parting tool on a part mounted between centers.** The part may bind on the cutter and result in a scrapped part or a broken cutting tool.

### Purpose of the rear mounted cutoff tool holder

The rear mounted cut-off tool holder allows you to use the cut-off tool from the back side of the part. Because the part is rotating "up" on the back side, the tool must be flipped over in the holder so that the cutting tip faces downward. This special holder raises the tool the amount needed to put the tip of the tool back to centerline height. This will save you time by allowing you to leave the cut-off tool holder mounted to the back side of the table while you use the regular tool post in its normal position on the front side of the part.

### Mounting the holder

This tool holder is mounted on the back side of the part, or the side away from the crossslide handwheel. Loosen the two clamping screws that hold the cutoff tool blade in place. Place the blade in the slot so the cutting tip is facing down. Lock it in position by tightening the two clamping screws. The only difference in using this tool compared to the standard cutoff tool holder is that the crossslide table is now cranked toward the operator to cut off a part.

### General instructions for "parting off"

Always try to lay work out so the cut-off tool is used as close to the spindle as possible. The post is designed so that the tip height should be aligned with the centerline of the part being cut. If for some reason yours is not exactly on the centerline, a shim can be placed under the front or rear of the holder to accomplish this.

Speed should be slower than normal turning speed, and feed rate should be a little heavy so the chip will not break up

in the slot. If speed and feed are correct there will not be any chatter, and the chip will come out as if it were being unrolled. Coolant (cutting oil) plays a major roll in this occurring properly.

If the tool chatters, first check to see if the work is being held properly. Then decrease speed (RPM) or increase feed rate or both. Once the blade has chattered, it leaves a serrated finish that causes more chatter. Sometimes a serrated finish can be eliminated by turning the spindle off, adding a liberal amount of cutting oil, bringing the blade up so there is a slight pressure on it without the spindle turning, and then turning the spindle by hand or as slowly as possible with the speed control.

### Sharpening the cutoff blade

To sharpen the blade, use the tool support on your bench grinder set in such a way that it will produce a 7° to 10° angle on the blade (top to bottom). (See Figure 1.)

FIGURE 1—Side view of blade.

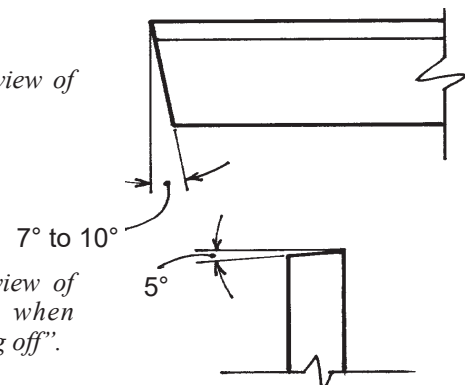

FIGURE 2—Top view of blade (enlarged) when ground for "parting off".

If you are sharpening the blade to "part off", the blade should have an additional angle of approximately 5° when viewed from the top with the point on the right. (See Figure 2.) Normally the angle would be as high as 15° but the .040" thickness of the blade would not be rigid enough and the blade could bend. If you want to cut grooves, don't put any angle on the blade when seen from the top.

If the cutting edges on the sides get dull, grind off the end of the blade until you get into new material where the edges are sharp to the cutting end. New blades are available as P/N 3086. Check the Cutting Tools Price List for current price.

Thank you,  
Sherline Products Inc.