

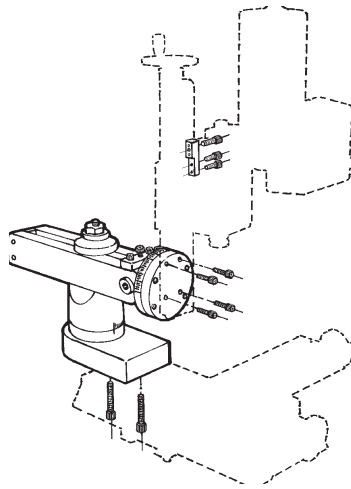

NOTE: A saddle travel extension is included with this kit to allow the column to be lowered an additional 1.6" so that small end mills can be used at or below the level of the mill table. Installation instructions start on page 6.



NOTE: This is a supplement to the instructions included in the *Sherline Assembly and Instruction Guide* that comes with each new machine.

8-Direction Mill Upgrade

P/N 5650 (Metric P/N 5660)

Using the multi-directional milling capabilities

The design of the 8-direction mill allows you to do everything that could be done with your present Sherline mill plus much more. Now angled holes can be drilled, or milling operations can be completed, V from almost any angle on parts mounted square to the table. The increased swing and movement of the column allows larger surfaces to be machined, eliminating the need for the horizontal milling conversion. Upgrading your present mill to match the capabilities of the Model 2000 8-direction mill is easy to do. The rectangular column of your present mill is replaced with the new round column. The base is extended by 2" with the base adapter. The bed and saddle unit from your present mill is attached to the new column.

Assembling a new 8-direction mill column upgrade

To assemble the multi-direction column, make reference to the exploded view provided on the last page of these instructions and complete the steps that follow:

1. Loosen the set screw holding the headstock to the saddle. Remove the headstock/motor/speed control assembly.
2. Remove the four socket head cap screws that hold the bed to the column base. Place the screws in the column holes so you don't lose them and set the column/saddle unit aside for now.
3. If your mill base is attached to a wooden board or bench, remove it so that you can get to the column base attachment screws on the bottom of the base. Remove the two socket head cap screws holding the column base to the bed. Retain the screws and set the old rectangular column base aside.
4. Attach the mill adapter base (P/N 5668) to the mill base using the two 1/4-20 x 1-3/4" socket head cap screws you just removed from the existing column base. The mill may now be reattached to its wooden base if you wish.

NOTE: The reason we use this adapter base when converting an existing mill is to compensate for the space that is lost

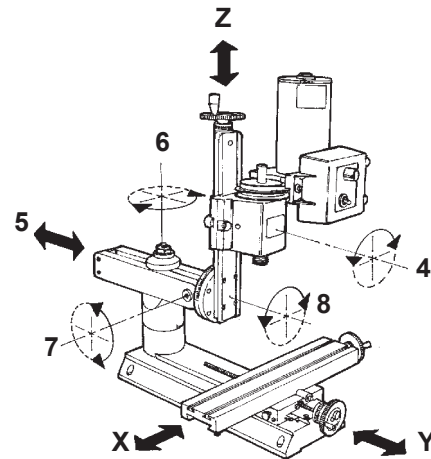

FIGURE 1—The axes of movement of a Sherline 8-direction mill. Shown is a Model 2000 mill, but the movements are the same on an upgraded mill.

due to the additional mechanism in the multi-direction column. It provides more usable adjustment area to improve the capacity of your mill. The model 2000 mill base was extended to 14" long so it does not need this adapter.

5. Screw the arm hold-down bolt (P/N 5613) into the top of the adapter base and tighten with an adjustable wrench. Two flat indentations are provided for the wrench to grip.
6. Slip the round column top (P/N 5655) over the pin and rotate it until the flat sides are parallel to the mill base with the engraved indicator line on the same side as the X-axis handwheel.
7. Reattach the column bed to the movable clamping disk (P/N 3517) which is on the end of the new column swing arm assembly. (**NOTE:** If you wish to install the optional column travel extension, see page 6 for special instructions at this point.) Replace the four 1" long socket head screws that originally held the bed to the column with the four 10-32 x 3/4" screws provided. Set the column bed to approximately a 90° angle to the

swing arm. Use an 11/16" or 17mm* wrench to tighten the flange nut (P/N 5623) on the shouldered bolt (P/N 5621) to secure the arm assembly in that position.

***NOTE:** A 17mm wrench usually works on an 11/16" hex nut but is a close fit. If your 17mm wrench is too tight and you don't have any inch tools you will have to use an adjustable wrench.

8. Set the swing arm over the column top (P/N 5655) and align it approximately square with the mill base and in about the center of its travel. Make sure the swing arm properly registers on the flats of the column top and is properly seated. While still holding the swing arm unit in place, set the hold-down washer (P/N 5620) over the end of the pin. Put a flange nut on the end of the pin and tighten it against the hold-down washer firmly to lock the swing arm in place.
9. Place the column adjustment block (P/N 5635) on top of the swing arm and attach it with two 10-32 x 5/8" socket head cap screws at both ends. Adjust the 1-1/2" long center bolt so that it is just touching the flat in the bottom of the relieved section in the top of the pivot knuckle when the head is at a 90° position. Final adjustment will be made after the head is "indicated in" in instructions that follow.

NOTE: If you remove the column adjustment block to accommodate a backward tilt movement of the column, make sure you replace it when returning the column to an upright position. The adjustment bolt not only helps you locate the 90° position, it also helps assure that the bed assembly cannot accidentally swing down and dent the mill table if the flange nut is loosened.

10. Reinstall the headstock/motor/speed control unit onto the mill saddle.

The mill is now ready to be positioned for use if you will be doing angled operations or ready to be squared up if you will be milling square parts. The following instructions will explain the steps used to "indicate in" the head of the mill so it will be square to the table.

The additional challenges of dealing with so many adjustments

Having so many adjustable components offers you many more possibilities, but it also brings with it additional challenges. You must make sure each of the adjustments is securely tightened before beginning your cut. Large clamping surfaces are provided which offer plenty of frictional area, so it is not necessary to overtighten the locking nuts and screws. Also, as you adjust your machine closer to the extremes of its movement, it is suggested that you take lighter cuts to reduce the possibility of flexing or vibration. Let common sense and experience be your guide here.

Obviously, the additional movements provided by an 8-direction mill column also mean more will be involved in returning the spindle to a square position in relation to the

table. This is the same procedure that must be used on full sized machines that offer similar movements. Being able to square up a mill is one of the skills that must be developed by any machinist. Using the laser engraved markings and the adjustment block provided with your Sherline mill will allow you to bring it back to a location very close to square. From there you will use dial indicators to "indicate in" the head the final few thousandths of an inch. The first few times you do it will probably take some time. The more often you do it, the faster it will go. Remember that alignment for small parts is less critical than if your cut will be traversing a longer distance. How accurately you must indicate in the head will be dictated by the parts you will be making.

NOTE: Before installing the adjustment block squaring fixture onto the swing arm, make sure there are no chips or debris in the pocket of the arm mount or on the end of the adjustment screw.

Precautions on overtightening

As with all adjustments on any machine, overtightening can distort components or ruin the built-in accuracy of your machine. This is particularly true on smaller machines where the power of the operator is much greater in relation to the size of the components than it is on larger machines. It is possible to deform the T-slot, which results in a worktable that isn't flat. I believe that the people who damage Sherline T-slots are the same people who break the T-slots on expensive hardened and ground tools. You have to develop a "touch" so this doesn't happen. It is very difficult to correctly square work up with the machine if the table is damaged and the work is "rocking".

MACHINING TIP: Use of a tooling plate (P/N 3560) is an inexpensive way to protect the surface of your mill table while providing a flat, versatile clamping surface.

Squaring up your mill

Determining the level of accuracy you really need

Squaring up a multi-direction mill can be a chore if you want "perfection". It is best to determine how accurate the setup must be before you start. The larger a close tolerance part is the better the setup required. An error of .001" (.025mm) per inch (25.4mm) would be a very small error on a part .4" (10mm) long. However, a part that is 5" long would have an error of .005". The type of machining that is going to be performed also has a bearing on the quality of the setup. As an example, a drilled hole doesn't usually require the quality of setup that would be used for a bored hole, (assuming the hole is being bored for accuracy rather than for lack of a drill of the proper size). The amount of work that will be done with the setup should be considered too. If your setup is just to do one particular job you only have to set it up close enough to do that job. If the setup will accommodate future operations as well, it should be adjusted to the tolerances of the most critical job. For example, squaring up a mill and vise to work on a number of precise parts is worth more of your attention than setting

up to drill one clearance hole in a noncritical part.

Limitations of the production process

Before starting you should realize that these mills are relatively inexpensive machine tools. They have accurately milled slides but the surfaces are not ground. To increase the accuracy of a Sherline tool only a percentage point would dramatically increase the price. We try to give a customer what we consider the most “bang for the buck.”

Why aren't there alignment pins to square up the machine?

If you are a novice to machining, you probably believe a machine should be designed so that a couple of pins could be dropped into holes, squaring up the machine and eliminating this whole process. After all, that is the way they do it with woodworking machinery. The truth is the tolerances that work well for wood cutting tools simply aren't accurate enough for most metalworking tools. You just can't hold the tolerances required with “pins”. When they fit tight enough to lock the head square to the table you can't remove them to do work that isn't square. They become more of a problem than the problem they were installed to eliminate. For example, an alignment or assembly error of .010" in a wooden kitchen table will never be noticed. Usually the floor it sits on is not even flat. It would be a waste of time and effort to make it more accurate than it has to be. On the other hand, a cylinder that has been bored out of square with the crankshaft in an automobile engine could wear the entire engine at an alarming rate. The piston goes up and down a million times in a normal day's use. The additional cost in fuel and shortened life demands accuracy. The multi-direction vertical milling column makes this accuracy possible by providing the adjustments required to suit a particular job.

Start by getting the column close to square with the table

The first place to start is to get the column approximately square with the table using the pointers and laser engraved scales on the machine. The first time you set it up you will have to use a machinist's square on the side-to-side column rotary adjustment as the pointer will not have been "zeroed in" yet. None of these adjustments must be extremely precise at this point because a finger type dial indicator will be used to make the final adjustments later. Remove the headstock/motor/speed control unit from the saddle. Place a machinist's square on the table and line up the front of the saddle to get the column approximately square front to back. Then line up on the right side of the saddle to get the column approximately square side to side. Reinstall the headstock assembly.

Check for any built-in error in your machine

(See Figure 2.) To check the built-in error of the machine use a dial indicator mounted in the spindle. Move the table under spindle with the Y-axis handwheel and note the error. This error will usually be around .001" to .002" (.05mm) in 3" (76mm). (Remember the components are not precision ground, they are precision milled.) When squaring the head this error should be accounted for. Remember you are

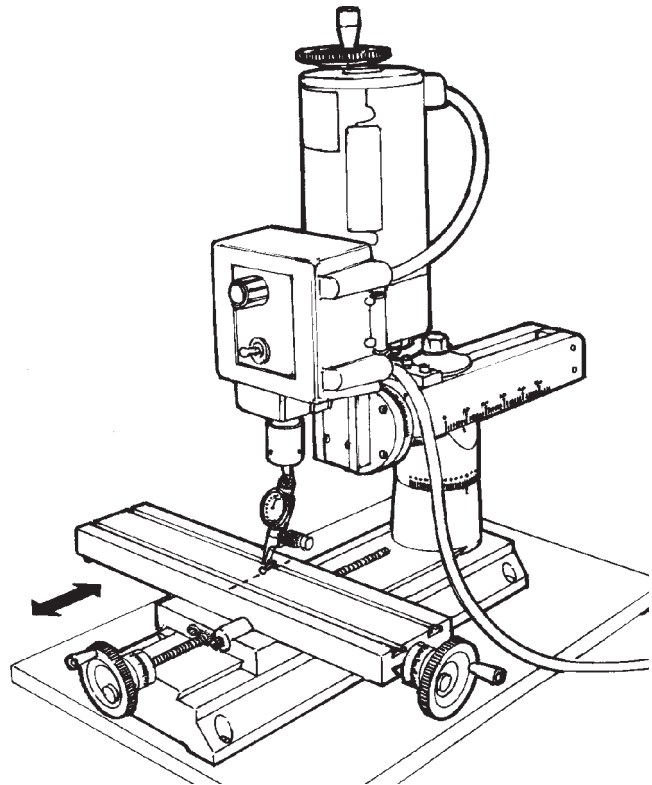

FIGURE 2—Checking for built in error in the table travel along the Y-axis. The indicator is shown held in an end mill holder but could also be held in a drill chuck.

squaring the head and spindle to base of the machine where the saddle travels, not the surface of the table itself. The head doesn't have to be square for this operation as long as you don't rotate the spindle since you are only checking for square in one direction. (NOTE: the illustrations show

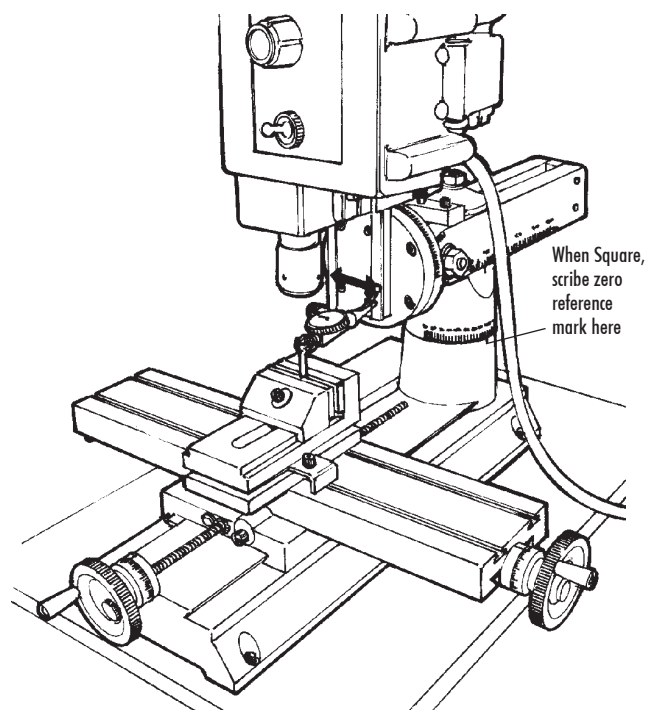

FIGURE 3—Squaring up the ram parallel to the Y-axis. The indicator can be held with a lathe chuck mounted to the table or a mill vise as shown here.

a Model 2000 mill base, but your upgraded mill is squared up in the same manner.)

Squaring up the ram

(See Figure 3.) The next decision to make is where the spindle is to be located. With all the adjustments that can be made with the 8-direction mill you'll probably start with the spindle located near the middle of the X/Y table movements. Something that isn't too obvious should be considered now. If the ram (the two-bar slide that allows you to move the head in or out and left or right) isn't square with the X-axis, the rotating column calibrations will have an error. To square up the ram, mount a dial indicator to the worktable and move the X-axis back and forth while reading the left and right surfaces of the column bed near the bottom. This only has to be done if you will be rotating the column and want to be able to rely on the angle graduation readings. Once set, lock the ram in place with the flange nut. With a steel scribe or X-Acto® knife blade, scribe a line on the column base opposite the "zero" mark on the angle scale for future reference. (See Fig. 3.)

Squaring the column with the X-axis

(See Figure 4.) The column should next be squared with the X-axis. This is accomplished with an indicator mounted in the spindle. Have the four socket head cap screws used to clamp the column rotation tight enough to keep the column from rotating, but not so tight that you can't move it with a light tap from a plastic mallet to the column bed. Because the axis that allows you to tilt the column in and out hasn't been squared yet you should only read the indicator at the same Y-axis location on the worktable that you used before. Offset the indicator at an angle in the spindle so that when the spindle is rotated it describes about a 2" to

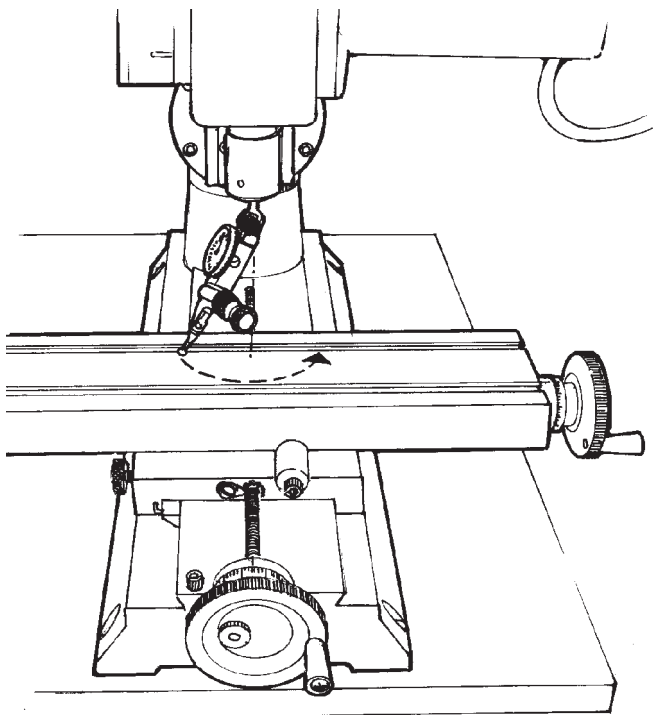

FIGURE 4—Squaring the left to right rotation of the column with the X-axis

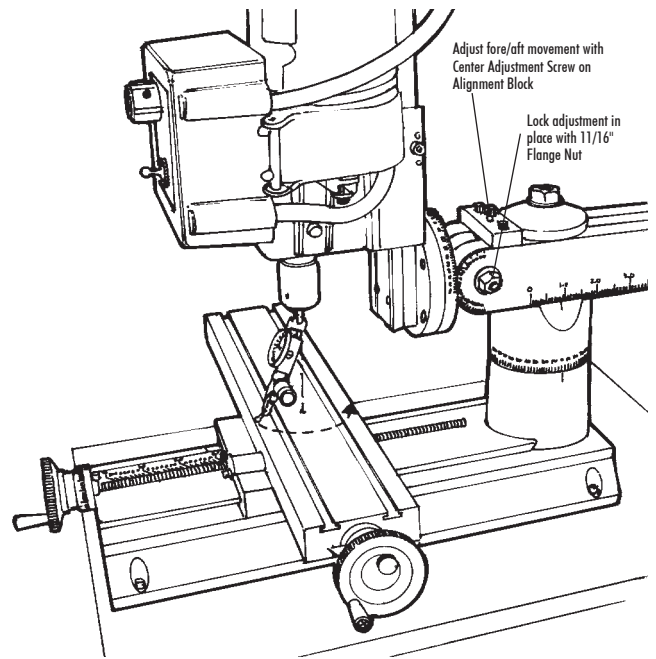

FIGURE 5—Squaring the fore and aft pivot movement of the column with the Y-axis

3" circle on the table. Take readings at the extreme left and right positions. Adjust the column with light taps until there is little difference in the readings at either extreme. I wouldn't try to get it perfect yet, just close enough so there isn't a gross error.

Squaring the column with the Y-axis

(See Figure 5.) Loosen the flange nut on the horizontal pivot pin so that the column can be moved using the adjustment screw in the alignment block but there is no slop in the assembly. The tilt is harder to set because the spindle doesn't rotate at the pivot point, but once you understand this, the task becomes simpler. The alignment block adjustment screw helps make fine adjustments in this direction easy. With the block in place and the flange nut loose the entire assembly is kept from falling forward by the adjusting screw. This block can be left in place unless the ram is completely retracted or the column is tilted back at an angle that interferes with the block. With the indicator still held in the spindle, take readings parallel with the Y-axis near the front and rear edges of the table. Raise or lower the column with the alignment block adjusting screw until the readings are the same front and rear. Remember the location of the pivot point and allow for it.

Example:

If the indicator reading is larger at the front of the table than the back, then that means the column must be tilted back. Say your reading is "0" at the back and .010" (.25mm) at the front. If you tipped the column back until the indicator read zero at the front, the reading at the back would not remain at "0" but would now be a negative reading. This is caused because the pivot point is located far enough behind the spindle so that both front and rear measuring points are still in front of it. Swinging the column back actually raises both points. The front point raises more than the back point, but both do go up. You will have to

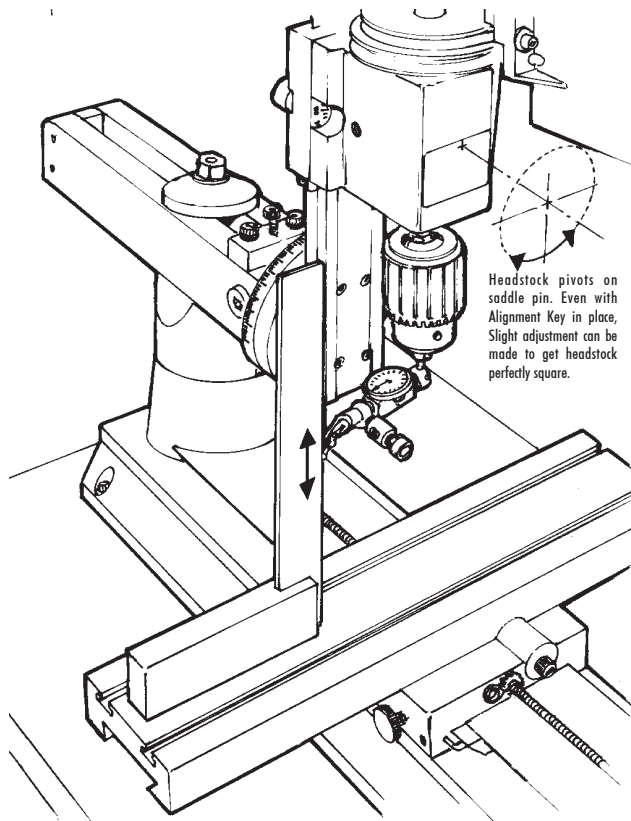

FIGURE 6—Fine tuning the headstock rotation alignment with a machinist's square and dial indicator

keep tilting the column back and measuring until you get the same reading front and back. This may require more movement than you first thought based on the difference between your initial measurements.

Fine tuning the headstock alignment

(See Figure 6.) It is time to make the final adjustments to the rotating column, but first I'll add a little more confusion to your life. Remember when I said that alignment pins are somewhat useless to line up a machine? Well, as much as I hate to admit it, in a sense we already have one. It is the alignment key that holds the headstock assembly square to the column saddle, which is mounted on the column bed. Removal of this key is what allows you to pivot the headstock on Sherline lathes and mills. It is one of the features that make our machines easy to use, versatile and very adaptable. It is also another thing you have to consider when searching for "perfect" alignment. If you have more than one key, don't mix them up because they are matched during assembly to fit as closely as possible. I have found the best way to deal with this potential problem is to push the head square against the key before tightening the cone point screw that locks the headstock in place. If you ever want to check alignment of the key to the column bed, mount a dial indicator in the spindle. Raise and lower the head while reading the vertical edge of a precision square. Adjust the rotating column until there is no error as the indicator moves up and down the square. Now read the table with the indicator. If the slot and key are perfect there shouldn't be any error but in most cases there will be

a small amount. This can usually be eliminated by taking advantage of what play does exist in the alignment key and slot. With the cone point set screw loosened slightly, tap the headstock with a plastic mallet to take out play in the direction you want to go. Then retighten the set screw.

Making final adjustments

The rotating column and tilting adjustments can be finalized so the indicator reads "0" as the spindle is rotated, however the error we measured when checking the table flatness could be accounted for now if need be. If the pointer on the back of the rotary column disk doesn't line up with the zero mark, loosen the screw holding it in place and reset it to indicate zero for future reference.

Your machine is now "indicated in" and ready to use. As you get a feel for your machine and go through this adjustment procedure a few times, the time it takes to get good results will decrease. Being able to accurately indicate in a mill is one of the skills that must be developed by any machinist who plans on making accurate parts. Though the adjustments on larger machines may be made in slightly different ways, the skills and procedures you learn here can be applied to other machines as well.

Using the optional column spacer block

In normal use a column spacer block will not be required. However, if you are working on a larger part or your setup requires more clearance under the swing arm, the optional spacer block can be used to raise the column an additional two inches. (Installation will be made easier if you first remove the headstock/motor unit to reduce the weight of the column.) To install the spacer block, remove the flange nut on top of the column hold-down bolt, and lift off the hold-down washer so that the entire column top and swing arm assembly can be lifted up and off of the hold-down bolt. Screw the extension bolt onto the end of the column bolt and tighten with an adjustable wrench. Slide the column spacer over the bolt and reinstall the column top and swing arm assembly. Reinstall the headstock/motor unit.

Lowering the headstock for working close to the table

To work down close to the table on thin stock or to run an end mill past the edge of the table, the column may be lowered by placing the column top (P/N 5655) above the swing arm instead of below it. Remove the flange nut, hold-down washer and swing arm. Place the swing arm over the hold-down bolt directly on top of the column base (P/N 5668). Place the column top back onto the hold-down bolt upside down and replace the hold-down washer and flange nut. Although you cannot use the alignment lines to help square up the head, this makes for a very strong and stable setup.

Engineering compromises

I'm always at odds with myself when I write instructions about a complicated procedure. By giving you this much information I know that I may be solving a problem for one customer by making them aware of it. At the same time I am probably confusing another customer who would never have noticed the problem because of the type of work that

the mill or lathe is being used for. I don't want to create a customer who spends all his time trying to achieve perfect alignment for work that doesn't require it and ends up never using the machine. Engineering is always a compromise. I deal with this fact with each new product that I design. While our machines aren't accurate enough for some customers, they are still too expensive for others. I hope you are pleased with the new capabilities this multi-direction mill can bring to your shop.

Thank you,
Sherline Products Inc.

NOTE: This instruction sheet is a supplement to the Sherline Assembly and Instruction Guide that comes with each new machine. For safety rules, operating instructions and information on the other components of the Model 2000 mill, consult that publication. It also includes basic instructions on metalworking that will be helpful for new machinists.

About the optional column travel extension

The saddle travel extension included with this column upgrade was devised for those who need to use small end mills and work down close to the table. It lowers the saddle by an additional 1.6". The trade-off that occurs with this modification is typical of many engineering compromises in that movement at the top of the travel is limited by the same amount gained at the bottom. Certain tall setups that involve multiple accessories can stack up to a height that may require more clearance at the top end. You will probably find that with the travel extension in place, you will need to purchase the optional column spacer block (P/N 56770) and extension bolt (P/N 56110). This spacer block will probably be left in place for most operations. Very tall setups may require even a second spacer block or removal of the travel extension to gain the required clearance.

Installing the saddle travel extension

Before installing your existing column bed to the rotating portion of the new column, make the following modifications to your column bed and leadscrew:

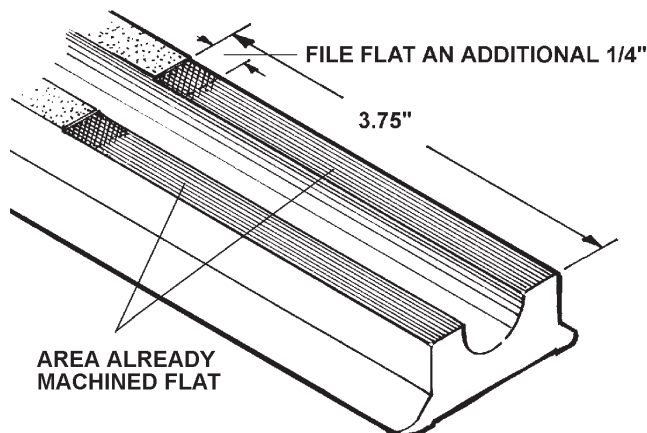

FIGURE 7—On older columns, file the top end of the mounting surface of the bed flat. You will be extending the machined flat surface an additional 1/4" or so for a total of 3-3/4" of flat.

1. Remove the leadscrew from the column. Do this by first removing the socket head cap screw that holds the saddle to the saddle nut. Then remove the countersunk screw at the top of the column that holds the leadscrew thrust to the column. The leadscrew, thrust and handwheel can now be removed as a unit.
2. On the bottom of the bed, a flat has been machined with enough clearance for your existing column base. On older columns, this flat will need to be extended approximately 1/4" with the use of a file. (See Figure 7.) Measure the flat on your column to see if it needs to be extended to total 3.75" long. A flat of this length is required to allow the column bed to be bolted flat against the movable clamp disk. Use a flat mill file and remove at least the same depth of material as was machined away on your column. Don't file any more of the length of the existing machined surface than is necessary. It is OK if you go a little deeper at the top end, as there is plenty of machined flat space to align the column. If you don't go deep enough, the column will not sit flat against the clamp disk.

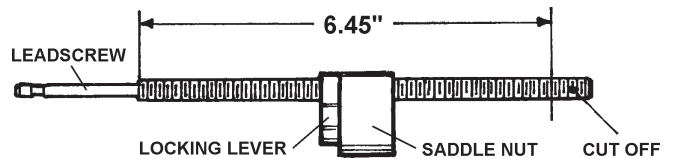

FIGURE 8—The leadscrew is shortened so that the thread length is 6.45". (Shown without handwheel.)

3. Your existing leadscrew must be shortened so that it will clear the top of the rotary column attachment. (See Figure 8.) Leave your existing saddle nut in place on the leadscrew. (If upgrading to a new saddle nut and locking lever, install them at this time.) By leaving

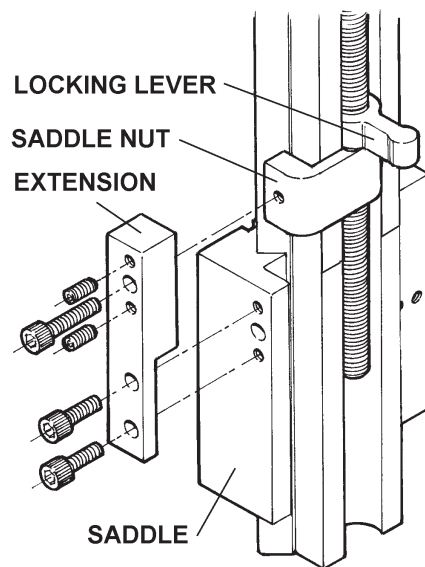

FIGURE 9—Saddle travel extension attaches to existing holes in the saddle. The old set screws are reused in new holes in the travel extension. The optional saddle locking lever is also shown.

your saddle nut in place, you will not have to thread it onto the leadscrew over freshly cut threads.

Mark the leadscrew with tape to show your cut location. The leadscrew should be shortened so that the new thread length is 6.45". Hold the leadscrew in a vise by gripping the end that will be cut off. Use a hacksaw to remove the excess length. Clean up and bevel the cut threads slightly with a file.

4. Set the leadscrew into the column and reattach the thrust to the column with the countersunk screw.
5. Remove the two backlash set screws from the side of the saddle and reinstall them in the two holes in the saddle travel extension.
6. Attach the extension to the saddle with two 10-32 x 1/2" SHC Screw provided. Do not tighten fully yet.
7. Return to step 7 on page 1 and continue with the reassembly of the column. When the installation is complete, readjust the Z-axis backlash using the two set screws in the travel extension. Position the saddle at the end of its travel as close to the handwheel as possible. With the attaching screw loosened, bring each set screw into light contact with the saddle nut and retighten the attaching screw. If binding occurs, readjust the two set screws until the leadscrew moves freely.

Thank you,
Sherline Products Inc.

Sherline Model 5650/5660 Mill Column Upgrade

Exploded View and Parts Listing

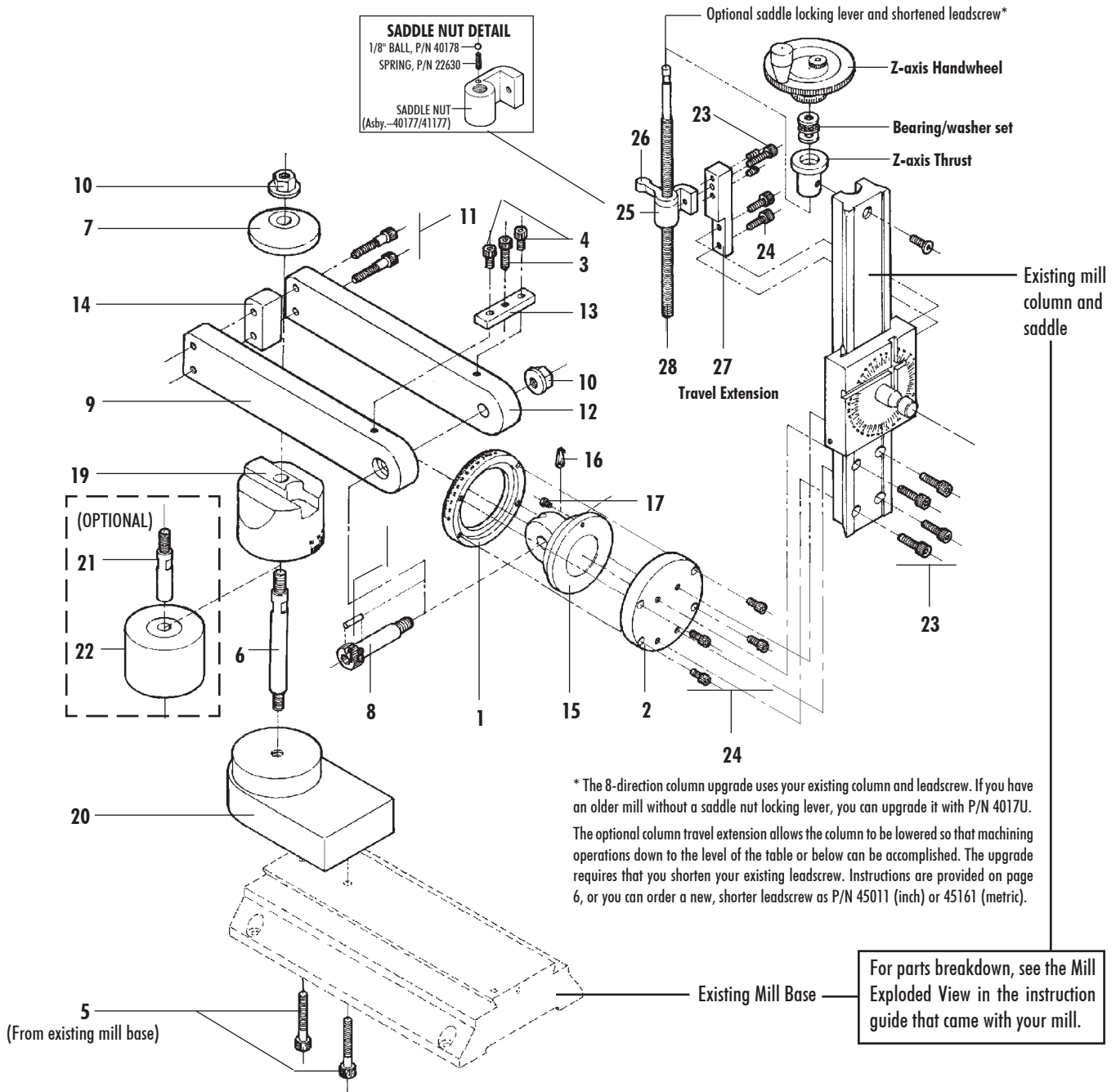

REF. NO.	PART NO.	NO. REQ.	DESCRIPTION	REF. NO.	PART NO.	NO. REQ.	DESCRIPTION	REF. NO.	PART NO.	NO. REQ.	DESCRIPTION
1	35160	1	Graduated Clamping Ring	10	56230	2	Flange Nut	20	56050	1	Mill #2000 Adapter Base
2	35170	1	Movable Clamping Disk	11	50220	2	1/4-20 x 1-3/4" SHC Screw	21	56110	1	Extension bolt
3	40340	1	10-32 x 1" SHC Screw	12	56330	1	Swing Arm side #2000	22	56770	1	Column spacer
4	40330	2	10-32 x 5/8" SHC Screw	13	56350	1	Column Adjustment Block	23	40690	5	10-32 x 3/4" SHC Screw
5	56240	2	1/4-20 x 1-1/2" SHC Screw	14	56400	1	Arm Spacer Block #2000	24	40670	6	10-32 x 1/2" SHC Screw
6	56130	1	Arm Hold-down Bolt #2000	15	56440	1	Arm Mount #2000	25	40177	1	Saddle nut w/ ball (Metric P/N 41177)
7	56200	1	Arm Hold-down Washer #2000	16	56450	1	Index Tab	26	40175	1	Saddle locking lever (Metric P/N 41175)
8	56210	1	3/8-16 x 2" Shouldered Bolt	17	50211	1	8-32 x 1/4" Button Head Screw	27	40176	1	Saddle travel extension
9	56220	1	Swing Arm side #2000	18	56470	1	3/32" x 1/2" Dowel Pin	28	45011	1	Z-axis leadscrew (Metric P/N 45161)
				19	56550	1	Model 2000 Column Top				