



PRECAUTIONS

- Poor connections can cause arcing, which can burn out motors or control chips. Always make sure plugs and connections are fully engaged and making good contact before powering up.
- Do not pull on wires to disconnect motor. Always grasp the plastic connector or the plug itself.
- In manual mode, crank handwheel no faster than 1 rev/second to avoid back-current.

SHERLINE PRODUCTS

INCORPORATED 1974

Installing Stepper Motors

Stepper Motor Installation Instructions

In order to prevent damage during shipment, some of the stepper motors have not been pre-installed. Install them using the following procedure:

1. If not already installed, carefully plug the white cable connector into the slot in the motor. Orient the motor so the plug is either on the right side or on the bottom to keep chips and coolant from causing a possible electrical short at the connection. If you wish, a small amount of silicon sealant or hot melt glue can be used to secure the white plug to the motor and seal the joint.
2. Note the location of the flats on the stepper motor shaft. Always assure that the coupling and handwheel set screws are tightened against the flat on the shaft. Tightening the set screw against the round part of the shaft can gall the shaft and make it impossible to remove from the coupling later.
3. Align the coupling set screw with the access hole in the side of the stepper motor mount and assure that the set screw is sufficiently released so that the motor shaft can be inserted.
4. Insert the motor shaft into the coupling, making sure the set screw is aligned with the flat. Keep the motor square to the mount so as not to flex the coupling during insertion. Loosely tighten the set screw.
5. Install three 8-32 x 3/8" socket head cap screws (SHCS) through the holes in the motor flange and into the stepper motor mount holes. Instead of a 4th screw in the four o'clock position use a tie wrap through that hole to secure the wire bundle from the motor. This will help relieve strain on the motor plug connection.

6. Assure that the flat on the motor shaft is still aligned with the coupling set screw (observe the position of the rear flat or handwheel set screw—the two flats are parallel) and tighten the coupling set screw. Install and turn the handwheel and observe the movement of the leadscrew to make sure everything is turning smoothly.

Using Handwheels on the Stepper Motors

When turning an unpowered stepper motor by hand you may notice a slightly "notchy" feel because of the permanent magnets in the motor. This is normal. When the motors are powered up they lock in position, and it will be very difficult to move them with the handwheels. Therefore, if you wish to use manual mode, you should first turn off the power to the motors using the ON/OFF switch on the external driver box or on the side of the computer if the driver box is built in. Turning a DC motor by hand causes it to act as a generator, sending current backward through the circuit. However, low amounts of current will not damage the board, so avoid cranking faster than about 1 rev/sec to be safe. For longer travels, use EMC's jog mode for approximate positioning, then turn off driver box power and use the handwheel for fine tuning.

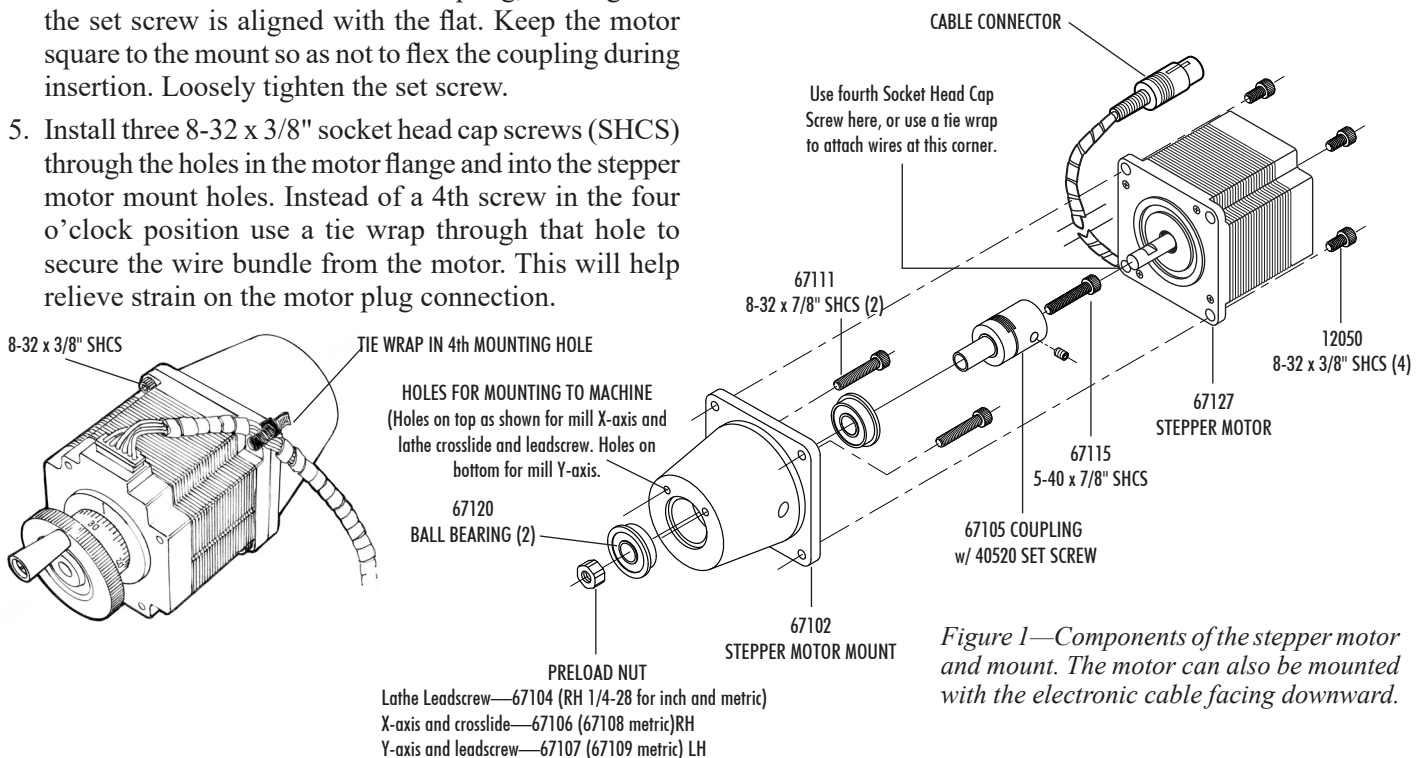
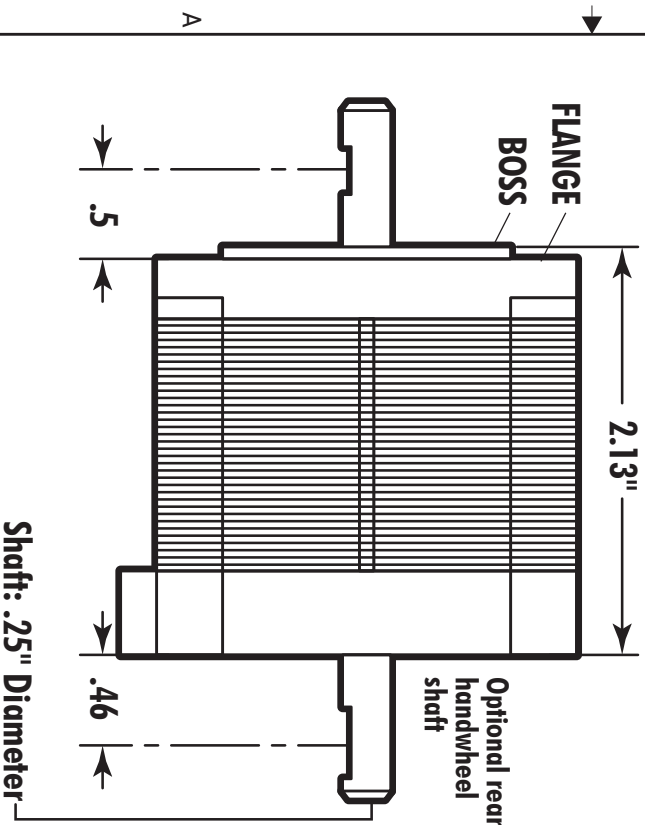
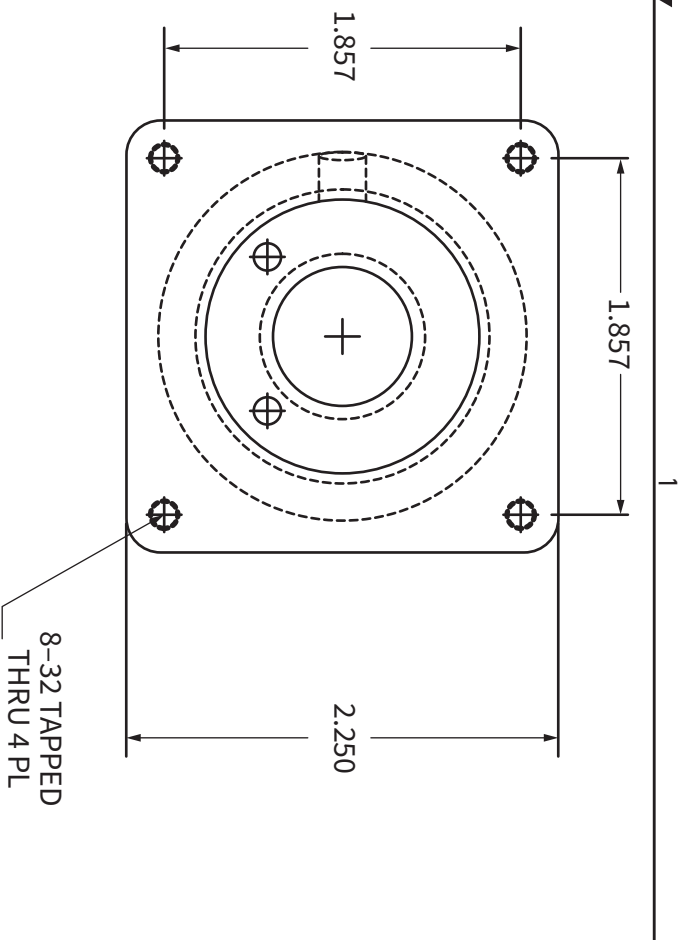
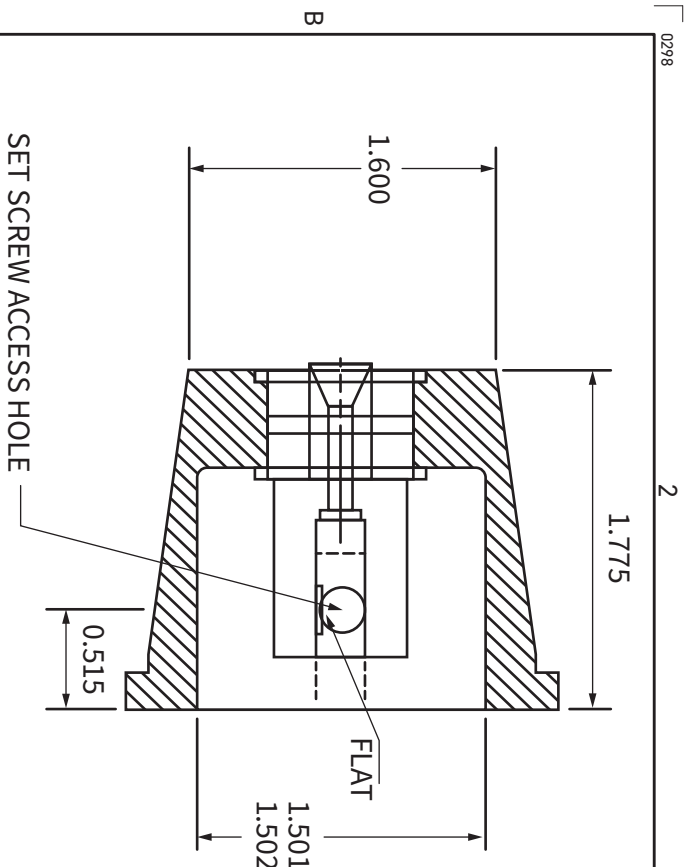

Figure 1—Components of the stepper motor and mount. The motor can also be mounted with the electronic cable facing downward.



If using a non-Sherline stepper motor, make sure to grind flats on the shafts as shown where the coupling and hand/wheel set screws contact the shaft.

Mounting Instructions

To mount the motor, start by turning the coupling set screw lines up with the access hole in the mount. Carefully insert the motor shaft into the coupling. With the flanges touching, rotate the stepper motor until the flat on the shaft is in alignment with the coupling set screw. Tighten the set screw. Rotate the motor to align with the motor with the 8-32 tapped holes. We usually attach the motor using three screws and use a zip tie in the fourth hole to secure the wire bundle.

If you decide to use Loc-tite® on the shaft set screw, a problem can occur if the motor has to be removed. What can happen is the shaft ends up glued to the coupling. If this occurs, loosen the preload nut until the motor and shaft can be backed out to expose the coupling so you can work on it. Be careful not to flex the coupling or it can break at the dampening slots.

DO NOT SCALE DRAWING !!!
UNLESS OTHERWISE SPECIFIED
DIMENSIONS ARE IN INCHES.

TOLERANCES ARE:
 DECIMALS .00 ±0.006
 DECIMALS .000 ±0.003
 ANGLES 1°
 DEBURR HAND
 HEAT TREAT NONE

FINISH BLACK ANODIZE

SHERLINE SHERLINE PRODUCTS, INC.

TITLE: **STEPPER MOTOR MOUNT**

DRAWN	JOE MARTIN	SCALE	1 = 1	SIZE	A	PART NUMBER	67102	REV.	1998-09
CHECKED	JOE MARTIN								
DESIGNER	JOE MARTIN	MATERIAL	3 5/16 ROUND 6061 T6					SHEET	1 of 1



SHERLINE STEPPER MOTOR SPECIFICATIONS—NMB MOTORS

Sherline P/N:	67127 (w/ DIN plug and flats on shaft) 67130 (no plug, flats on shaft)
Manufacturer:	NMB (Minebea Co. Ltd.)
Mfg. P/N (Type):	23KM-K035-62V (double shaft)
Frame size:	NEMA #23
Step angle:	1.8°
Voltage:	3.2 V DC
Current:	2.0 A/Φ
Resistance:	1.6 Ω/Φ
Inductance:	3.6 mH/Φ
Holding torque:	.775 N.m (Newton meters) 7.9 kg-cm 109.71 oz/in (ounce inch) 6.856 in/lb (inch pound)
Rotor inertia:	250 g-cm ²
Number of wire leads:	6 (See color code diagram FIG. 2)
Weight:	1.32 lb (0.6 Kg.)
Length:	2.13" (54 mm)
Shaft:	Double ended, 1/4" diameter

See figure 3 for the pin diagram and wire color layout of the stepper motor connector cables we supply with our stepper motors. Since there is no industry standard for wire colors in this field, if using a connector not supplied by Sherline each pin and color should be confirmed with a continuity tester before applying power.

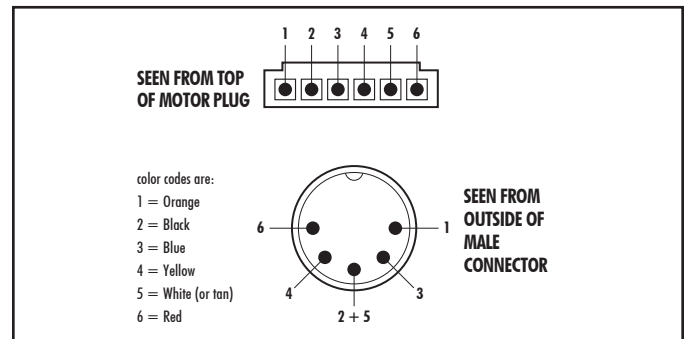

FIGURE 3: diagram shows which pin in the DIN connector is wired to which position in the motor connector.

NOTE: Motors can be wired in either unipolar or bipolar configuration depending on how the leads are connected. Sherline motors with plugs are wired for unipolar operation.

PRECAUTIONS

- Make sure the ends of raw wires are not touching each other when turning the handwheel by hand to drive the stepper motor and leadscrew. It can cause the motor to feel rough and hard to turn.
- DC motors generate current when hand cranked that can damage the control unit. When positioning a stepper motor by hand using the handwheel, do not crank faster than about 1 rev/second. For long travels, use the jog mode of your CNC control software.
- Poor connections can cause arcing, which can burn out motors or control chips. Always make sure plugs and connections are fully engaged and making good contact.
- Always turn off driver box power before plugging in or unplugging a stepper motor.

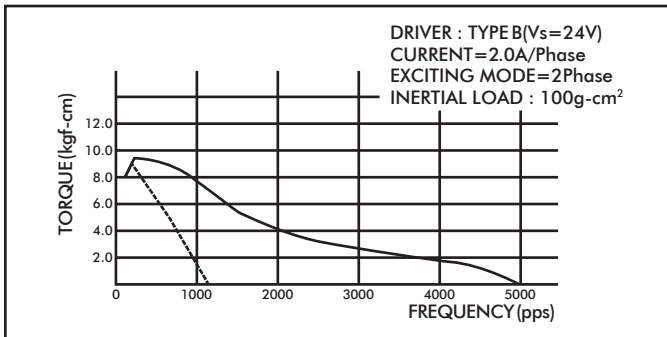

FIGURE 1—Motor torque curve

Lead Wire Connection and Color Code

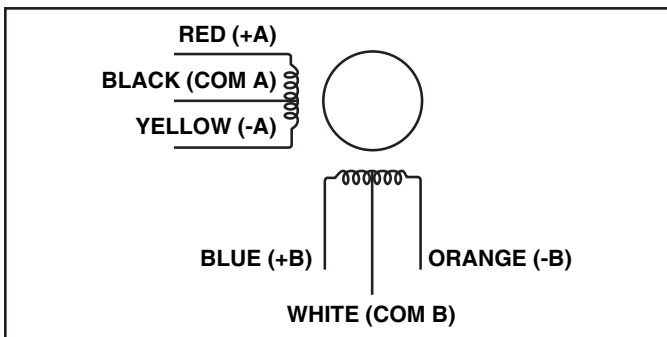

FIGURE 2— Color of internal wiring for NMB motors