



## Z-axis Backlash Lock

P/N 4017Z/4117Z

### The Purpose of the Z-axis Backlash Lock

CNC machining operations require precise Z-axis movement to producing a good part. The normal backlash of .003" to .005" can be unacceptable in these situations and a way was needed to reduce backlash to the .001" to .002" range. The problem would arise when the Z-axis gibs were set so tight to eliminate vibration that the headstock had to be physically pushed down. This would leave backlash between the cutter and the part. With the normal vibration of making a cut and the tendency of an end mill to pull itself down into the part, the headstock would slowly lower the amount of this backlash. Sherline owners found ways to work around this problem when working with manual machines, but it soon became apparent that this was a problem that was unacceptable for CNC machining. This problem has been solved without adding excessive cost to Sherline mills. We designed this lever to lock the leadscrew a couple of years ago, but we never thought of it as an option that could be used to control backlash. Once we realized this lock could be used in this way, we had a prototype working the next day and were into production within a week. We are also pleased to report that the anti-backlash system can be added to every Sherline mill or vertical milling column ever built!

By locking this lever against the Z-axis saddle nut, it keeps the leadscrew from turning once the headstock is positioned at the proper height for the operation. This new lever positioning system will allow you to position the locking lever in a partially locked position, removing as much backlash as you desire, and then it can be locked in that position. As wear occurs, the position of the locking lever can be adjusted.

*NOTE: If you are retrofitting this system to an older mill, you will find more complete installation instructions on the other side of this sheet.*

### Installing and Using the Z-axis Lock on a CNC Mill

The locking arm is clamped in the lock plate for shipping. Loosen the knurled thumbscrew and remove the plastic arm. Insert the pin in the end of the plastic lever into the hole in the end of the brass Z-axis locking lever from the bottom side. Align the locking arm with the slot in the lock plate and slip it in. Move the brass locking lever to provide the desired amount of backlash. Tighten the thumbscrew to hold the plastic arm in position. Do not overtighten the thumbscrew. There is not a lot of force trying to move the arm. The arm serves only to hold the locking lever in

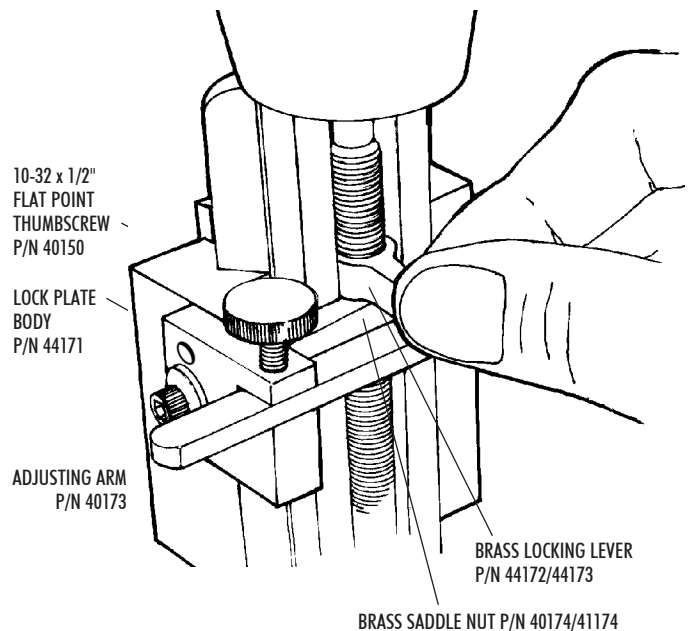

FIGURE 1—Components of the lever locking system as they are now installed on new Sherline CNC mills.

position once you have adjusted it.

The brass locking lever is adjusted by hand as shown in Figure 1, and then the positioning arm is locked in place. Don't adjust the locking lever by moving the plastic arm directly. You will have much better feel for the amount of pressure needed by adjusting the locking lever itself.

### Installing on Older Mills that Have a Locking Lever

Manual mills made before 1/04 and equipped with a locking lever on the leadscrew do not have a center hole in the end of the locking lever for insertion of the pin on the end of the adjusting arm. It will be necessary to drill a 3/32" hole in the center of the enlarged portion of the arm before the pin can be installed.

### Installing a New Saddle Nut and Locking Lever on a CNC Mill Not Currently Fitted with a Locking Lever

Prior to January, 2004 newer Sherline manual mills came with a locking lever but CNC mills were shipped without one to prevent accidental locking which might ruin a part. The new retrofit installation kit includes a new locking lever and a new saddle nut without the spring loaded ball to hold it in the unlocked position. The positive locking arm allows partial locking of the lever to reduce backlash

to a minimum. The small detent in the locking lever that was formerly used to engage a spring-loaded ball has been retained to indicate the side of the locking lever that should be facing the saddle nut. (If the locking lever should fail to lock against the saddle nut within the available arc in the back of the mill column, check to see if the lever has been installed backwards.) Install the new saddle nut and lever as follows:

1. Remove the socket head cap screw that now holds the saddle to the existing saddle nut and set it aside.
- 2a. (Non-CNC mills) Remove the countersunk screw from the top of the column bed that holds the leadscrew thrust to the bed. The leadscrew and thrust can now be removed as a unit.

or

- 2b. (CNC mills) Through the hole in the side of the stepper motor mount, loosen the set screw that tightens against the motor shaft. Then remove the three or four screws holding the stepper motor to the stepper motor mount. From inside the mount you can now remove the two screws that hold the mount to the column. This will allow you to lift off the stepper motor mount and leadscrew as a unit.
3. Unscrew the old saddle nut from the leadscrew. Thread the new locking lever (with the ball detent facing the free end of the leadscrew) and then the new saddle nut onto the leadscrew. Make sure the saddle nut is installed in the same direction as the one you previously removed. Once both are installed, screw them onto the leadscrew to approximate position and leave them just lightly touching each other but not locked.
4. Reattach the leadscrew and thrust to the column bed.
5. Slide the saddle into position so the hole aligns with the hole in the saddle nut.
6. Using the appropriate new, longer socket head screw and washer for your mill as shown in Figure 2, feed the screw through the hole in the new locking plate, through the hole in the saddle and into the threaded hole in the saddle nut to reattach it.
7. Insert the pin of the plastic arm into the hole in the end of the brass locking lever from the bottom. Slide the arm into the slot on the end of the locking plate and lightly secure it in the desired position using the knurled thumbscrew.
8. Adjust backlash as noted on side 1 of this sheet.

#### Adjusting the Saddle Nut Alignment

When you reinstalled the new saddle nut in place of the old one, the two adjusting set screws were left in their previous adjustment. If binding occurs in the new installation, it will be necessary to readjust the new saddle nut on the leadscrew using the two set screws on either side of the attachment screw. To do this you will first need to remove the locking plate to get access to these screws. Then, to

adjust the saddle it should first be positioned at the end of its travel as close to the handwheel as possible. Remove the lock plate and loosely install the original shorter screw that attached the saddle to the old saddle nut. Bring each set screw into light contact with the saddle nut and retighten the screw. If binding occurs, readjust the two set screws until the leadscrew moves freely. Then remove the shorter screw and reinstall the locking plate and new, longer screw and tighten.

What we are attempting to accomplish is to have the saddle nut ride on the leadscrew with the minimum amount of drag. You can check the drag by turning the leadscrew handwheel. If you feel excess drag, tighten or loosen a single set screw while moving the saddle with the handwheel until the handwheel turns freely, but keep the saddle close to the handwheel. If you adjust the saddle nut while it is in the center of the leadscrew, it may be slightly off center but will feel free until the saddle gets close to either end of its travel. Here, the leadscrew is supported and cannot deflect so it will bind the most. If you can't eliminate the binding, tap the saddle nut with a plastic hammer on the leadscrew side while the saddle nut is tightly attached to the saddle and readjust. Don't use the machine with a loose attachment screw, as this will cause excessive wear and backlash.

Thank you,  
Sherline Products Inc.

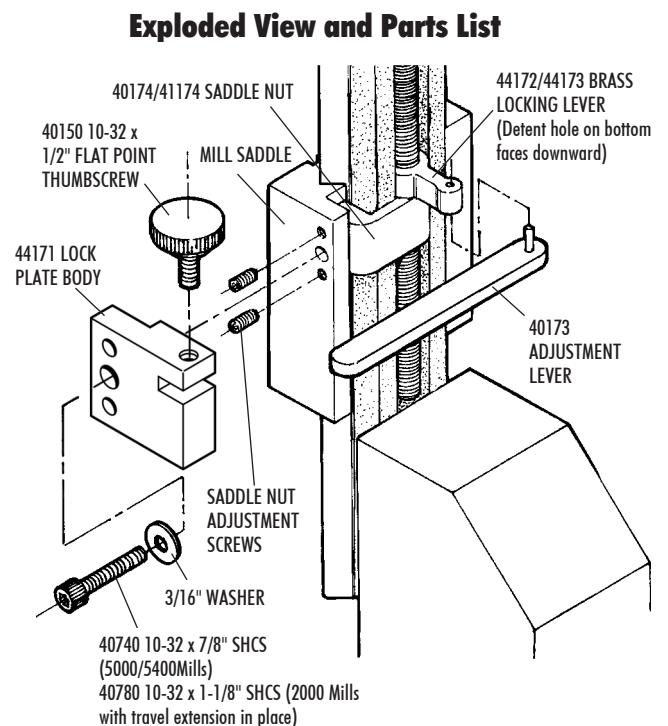

FIGURE 2—Exploded view shows saddle nut and locking lever installed on the leadscrew with the other parts of the Z-axis lock called out.