



Mill upgrade kit part numbers:

- P/N 6700/6710—Model 5000/5400 mills
- P/N 6705/6715—Model 2000 mill
- P/N 6740/6745—Model 5000/54000 Z-axis only
- P/N 6750/6755—Model 2000 Z-axis only
- P/N 6758/6758M—Model 5800/5810 mills
- P/N 6760/6765—All mills, X-axis only
- P/N 6770/6775—All mills, Y-axis only

NOTE: The instructions provided here cover all axes on all mill models. If your kit is for just one axis, not all of these instructions will apply to your particular installation.



Installing CNC Stepper Motor Mounts on a Sherline Mill

Using the Template Blocks to Locate New Mounting Holes for the Stepper Motor Mounts

This kit contains two template blocks that will help you locate the holes needed to fit stepper motor mounts to your existing Sherline lathe or mill. (Sherline machines now in production have the table and mill base holes predrilled to make this job easier.) The rectangular block is used for the lathe crossslide table and mill table as well as the mill base. The round template is used for the lathe bed (leadscrew) and the mill column bed (Z-axis). These blocks are not hardened, because they will only be used once or twice and the wear on them will be minor. To drill the hole pattern for the stepper motor mount for each axis, follow the steps below:

1. Using the handwheels, move the table and saddle so that they are as close to the handwheel as possible.
2. On models with standard handwheels, break loose the 5-40 screw in the center before removing the handwheel. The handwheel gives you a way to hold the leadscrew while breaking the center screw loose.
3. Remove the handwheel by loosening its set screw with a 3/32" hex wrench and pulling it off the shaft. (For adjustable "zero" handwheels, rotate the collar until the hole lines up with the set screw.)
4. Remove the leadscrew thrust from the appropriate base, table or column. It is held on by a single 5-40 screw. The mill column thrust is held in place by a countersunk screw through the bed.
- 4A. X- and Y-axes—Remove the 5-40 screw from the end of the leadscrew. Set aside leadscrew end, thrust and 5-40 screws. They are no longer needed. (On machines with adjustable zero handwheels, use pliers with plastic jaws to hold the leadscrew or protect the leadscrew threads in some other way while holding it to break loose the 5-40 screw.)
- 4B. For the Z-axis only, remove the screw that holds the saddle nut to the saddle. (Hold the saddle so it doesn't drop when the screw is removed.) Remove the leadscrew and saddle nut. A new leadscrew is provided. It is already attached to the stepper motor mount. Reinstall your old saddle nut on the new leadscrew. (If you have a Z-axis locking lever, it is not used when converting to CNC use.)
5. Bolt the template parallel to the table or base to be drilled using the center hole and one of the 5-40 SHCS provided with the kit. Once level with the table, clamp it in place so it can't move.
6. Using a "C" clamp, clamp the template to the column or lathe bed with the hole pattern leveled. (See Fig. 2.) Measure the height of each hole from the top surface unless you are pretty good at knowing when something is level by eye. It is not critical to its function that the

stepper motor be mounted level, but it looks much more professional when it is.

7. Using the holes in the template as a drill guide, start each hole about 1/16" deep with a #29 or 0.136" drill.
8. Remove the template block and finish drilling the holes to 0.25" deep, backing the drill out to clear chips, add cutting oil and finish drilling the hole in two more steps until a depth of 0.5" is reached. Countersinking the holes will make it easier to start a tap.
9. Tap the holes to 8-32 to at least 0.4" deep. Be sure to use cutting oil. Remember that you are working on part that is relatively expensive to replace. Take your time. Remove any burrs from the surface of the part after tapping the hole.

Installing the Stepper Motor Mount

1. Before you start, look at the cross-section view in Figure 4 and at the exploded view for the parts list. One of the

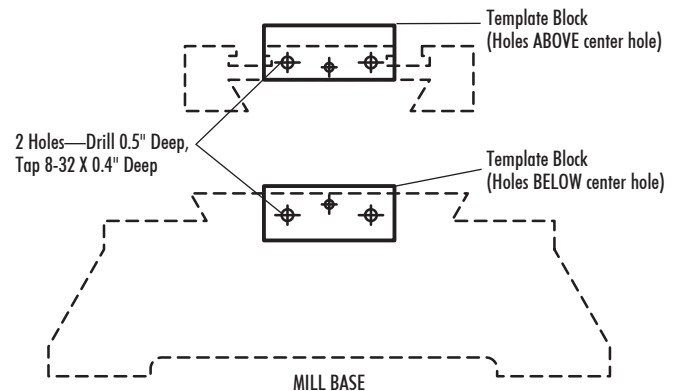

FIGURE 1—The rectangular block is used for the lathe and mill tables as well as the mill base. On the tables, the two new drilled holes are **ABOVE** the existing center hole, while on the mill base, the two new holes go **BELOW** the center hole as shown in the drawings above. Note that on mills made after 2002 these holes may already be in place.

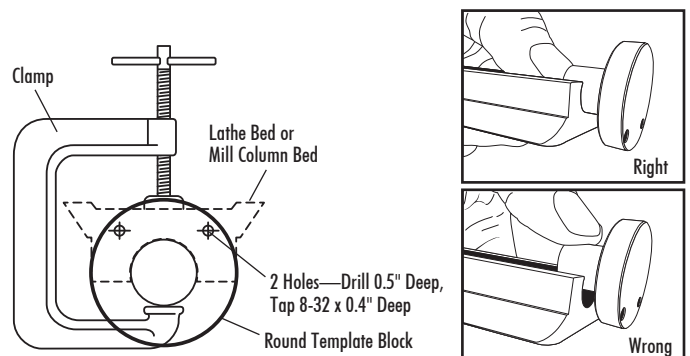

FIGURE 2—The round center of the template block registers in the center portion of the lathe bed, not on top. Rotate the template until the holes are level and clamp in place while starting holes.

most important parts of the assembly is to be sure that the preload nut is installed with the counter bore facing the bearing.

2. Thread the proper preload nut onto the leadscrew based on its direction of rotation (left-hand or right-hand). **Note:** The C bore side of the preload nut must be facing the bearing as shown in the exploded view on the following page.
3. Slide the stepper motor mount over the X- or Y-axis leadscrew end.
4. Push a coupler through the bearings and over the tapered end of the leadscrew. Attach it to the leadscrew with the new 5-40 screw provided. To tighten, put a hex key through the hole in the side of the mount and into the coupler set screw. Hold the key to keep the shaft from turning while tightening the 5-40 SHCS in the end of the coupler. (See figure 3.) The access hole is now on the side of the mount rather than on the bottom as is shown here.

FIGURE 3

Keeping the leadscrew from turning while tightening 5-40 screw and the preload nut

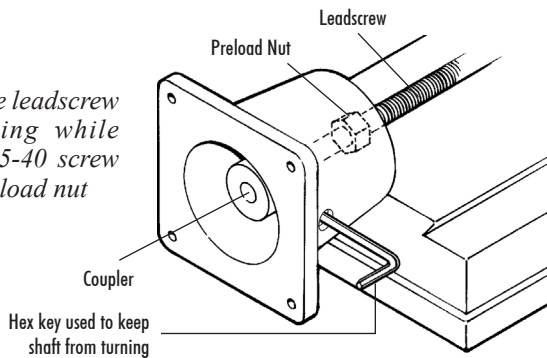

NOTE: The hex key adjustment hole may be located on either side depending on the axis. On older models the hole may be on the bottom instead of the side as is shown here.

4. Using a 3/8" wrench, adjust the preload nut snugly against the bearing. (Note the direction of rotation; i.e., left- or right-hand threads.) Tighten it enough to remove all endplay. (See Figure 4 to understand how the nut preloads the bearings.) Turn the coupling by hand to make sure it turns freely, then put a little LocTite® on the threads behind the preload nut and let capillary action draw the fluid in. Figure 3 shows how to use a hex key through the hole in the mount to keep the coupler from turning while tightening the preload nut.
5. With the leadscrew screwed into the mill saddle as far as practical and the table moved to its extreme left position, attach the stepper motor mount to the table, base or bed by installing two 8-32 x 3/4" SHCS provided. They go inside the motor mount and thread into the new holes in the bed, base or table. Before tightening the screws, turn the coupler by hand to make sure the mount is properly aligned and is not putting tension on the leadscrew. The holes in the mount are slightly oversize to allow for minor alignment adjustments. Check for proper alignment by again hand-turning the coupler to assure there is no binding after final tightening of the screws.
6. Put the Z-axis leadscrew/stepper motor mount assembly in place and re-attach the saddle nut to the Z-axis saddle using the screws removed previously. It will be necessary to readjust Z-axis saddle nut after installation. (See instructions that follow.)

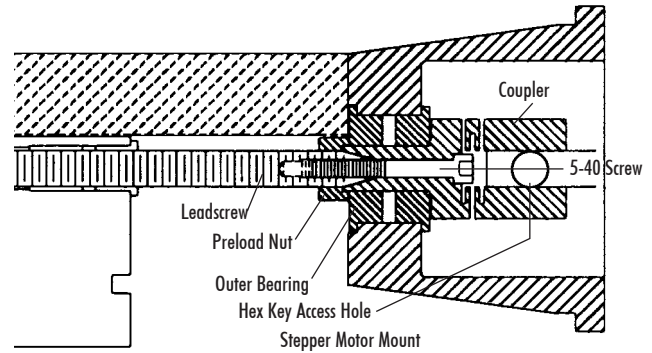

FIGURE 4—A cross-section of the stepper motor mount shows how the coupler is attached to the leadscrew.

Attaching a Stepper Motor to the Mount

Sherline stepper motors come with a flat machined on the shaft in the proper location. If you are using another stepper motor, a flat must be filed or machined where the coupling set screw is to be tightened against it. See the cross-section on the attached sheet for location of the flat. File a flat or use your mill to machine a flat on the shaft. (If a flat is not provided, the set screw will raise a burr, making it difficult or impossible to remove the shaft from the hole later.) Push the shaft into the coupling and tighten the set screw on the flat. Attach the stepper motor to the mount using the three SHCS provided. The fourth hole can be used for a “cable tie” to secure the cable or for a fourth screw at your discretion. Attach a handwheel to the shaft on the other end of the stepper motor.

Adjusting the Z-Axis Saddle Nut

(Following is a review of how to adjust the saddle nut after the new Z-axis leadscrew is installed.)

The adjustment for the saddle nut consists of two flat set screws on either side of a 10-32 socket head cap screw. With the saddle nut located on the leadscrew close to the stepper motor mount, loosen these two screws and slide the saddle into position over the saddle nut. Put the 10-32 socket head cap screw through the saddle and screw it into the saddle nut, but do not tighten it yet.

Adjust the set screws until the flat points touch the saddle nut, and then tighten the 10-32 socket head cap screw. Watch as you tighten to see that the leadscrew doesn't move. If it does, loosen the screw, readjust the set screws and retighten.

What we are attempting to accomplish is to have the saddle nut ride on the leadscrew with the minimum amount of drag. You can check the drag by turning the leadscrew handwheel. If you feel drag, tighten or loosen a single set screw while moving the saddle with the handwheel until the handwheel turns freely, but keep the saddle close to the handwheel. If you adjust the saddle nut while it is in the center of the leadscrew, it may be slightly off center but will feel free until the saddle gets close to either end of its travel. Here, the leadscrew is supported and cannot deflect so it will bind. If you can't eliminate the binding, tap the saddle nut with a plastic hammer on the leadscrew side while the saddle nut is tightly attached to the saddle and readjust. Don't use the machine with a loose attachment screw as this will cause excessive wear and backlash.

Thank you,
Sherline Products Inc.

KIT FOR SHERLINE MILLS, MODEL 5000/5100, 5400/5410, 2000/2010

Parts List , Sherline CNC Mount Upgrade

NO. REQ.	PART NO.	DESCRIPTION
12	12050	8-32 x 3/8" SHCS (To attach stepper motor to mount)
3	40520	10-32 x 3/16" cup point Set screw
1	67028/67029	CNC Z-axis leadscrew (5000/5400-series)
1	67030/67031	CNC Z-axis leadscrew (2000-series)
3	67102	Stepper motor mount, X, Y and Z axes
1	67103	Stepper motor mount cap
1	67104	Preload nut (RH) (1/4-28, used for both inch and metric)
3	67105	Coupler
1	67106/67108	Preload nut (RH)
1	67107/67109	Preload nut (LH)
6	67111	8-32 x 3/4" SHCS
3	67115	5-40 x 7/8" SHCS
1	67116	CNC template, bed bushing (round)
1	67117	CNC template, slide bushing (rectangular)
6	67120	Bearing

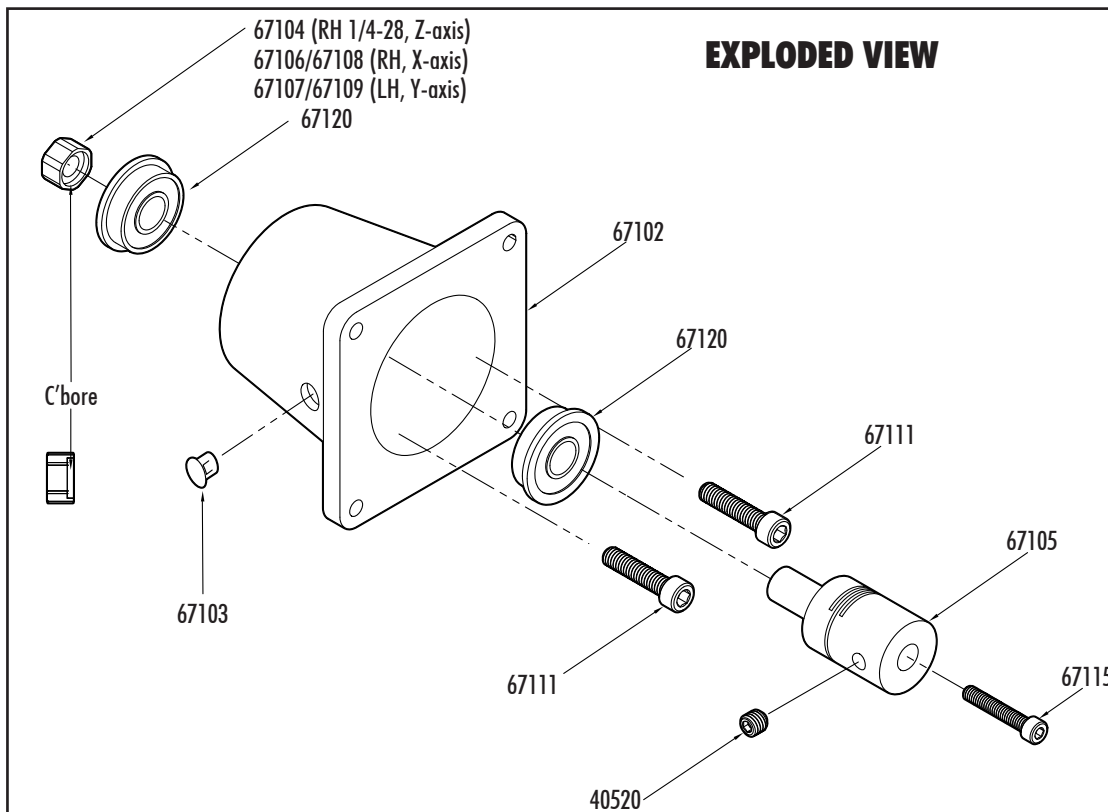



PRECAUTIONS

- Poor connections can cause arcing, which can burn out motors or control chips. Always make sure plugs and connections are fully engaged and making good contact before powering up.
- Do not pull on wires to disconnect motor. Always grasp the plastic connector or the plug itself.
- In manual mode, crank handwheel no faster than 1 rev/second to avoid back-current.

SHERLINE PRODUCTS

INCORPORATED 1974

Installing Stepper Motors

Stepper Motor Installation Instructions

In order to prevent damage during shipment, some of the stepper motors have not been pre-installed. Install them using the following procedure:

1. If not already installed, carefully plug the white cable connector into the slot in the motor. Orient the motor so the plug is either on the right side or on the bottom to keep chips and coolant from causing a possible electrical short at the connection. If you wish, a small amount of silicon sealant or hot melt glue can be used to secure the white plug to the motor and seal the joint.
2. Note the location of the flats on the stepper motor shaft. Always assure that the coupling and handwheel set screws are tightened against the flat on the shaft. Tightening the set screw against the round part of the shaft can gall the shaft and make it impossible to remove from the coupling later.
3. Align the coupler set screw with the access hole in the side of the stepper motor mount and assure that the set screw is sufficiently released so that the motor shaft can be inserted.
4. Insert the motor shaft into the coupling, making sure the set screw is aligned with the flat. Keep the motor square to the mount so as not to flex the coupling during insertion. Loosely tighten the set screw.
5. Install three 8-32 x 3/8" socket head cap screws (SHCS) through the holes in the motor flange and into the stepper motor mount holes. Instead of a 4th screw in the four o'clock position use a tie wrap through that hole to secure the wire bundle from the motor. This will help relieve strain on the motor plug connection.

6. Assure that the flat on the motor shaft is still aligned with the coupling set screw (observe the position of the rear flat or handwheel set screw—the two flats are parallel) and tighten the coupling set screw. Install and turn the handwheel and observe the movement of the leadscrew to make sure everything is turning smoothly.

Using handwheels on the stepper motors

When turning an unpowered stepper motor by hand you may notice a slightly "notchy" feel because of the permanent magnets in the motor. This is normal. When the motors are powered up they lock in position, and it will be very difficult to move them with the handwheels. Therefore, if you wish to use manual mode, you should first turn off the power to the motors using the ON/OFF switch on the external driver box or on the side of the computer if the driver box is built in. Turning a DC motor by hand causes it to act as a generator, sending current backward through the circuit. However, low amounts of current will not damage the board, so avoid cranking faster than about 1 rev/sec to be safe. For longer travels, use EMC's jog mode for approximate positioning, then turn off driver box power and use the handwheel for fine tuning.

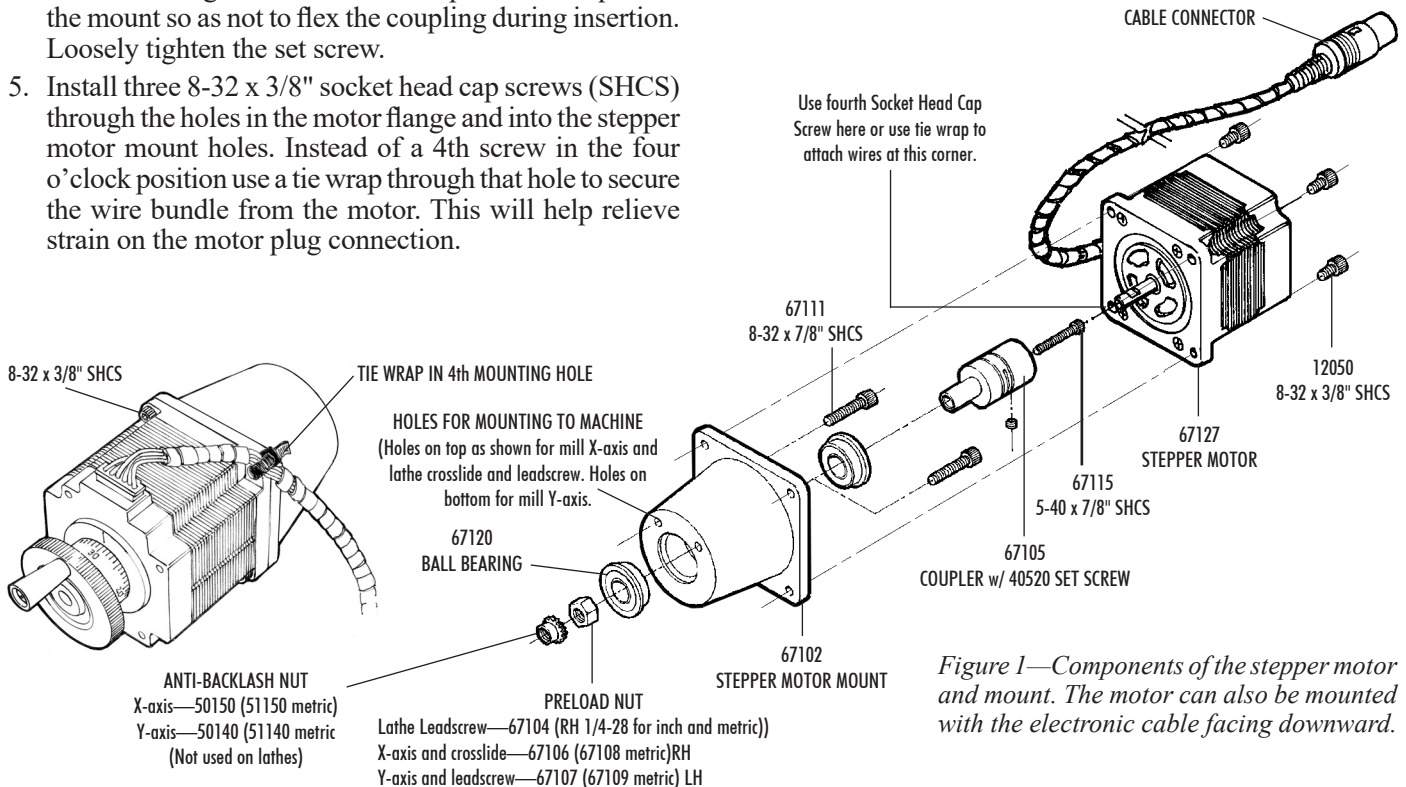
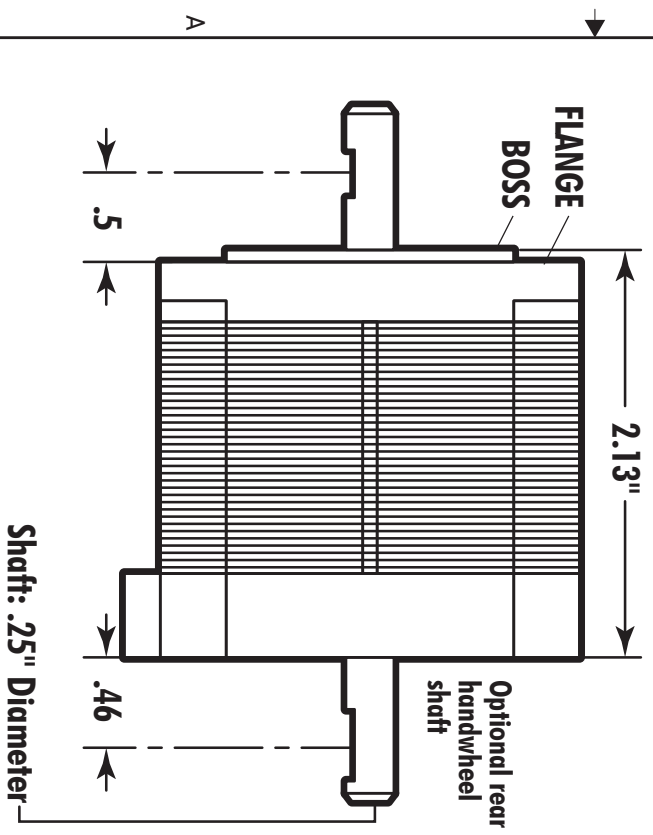
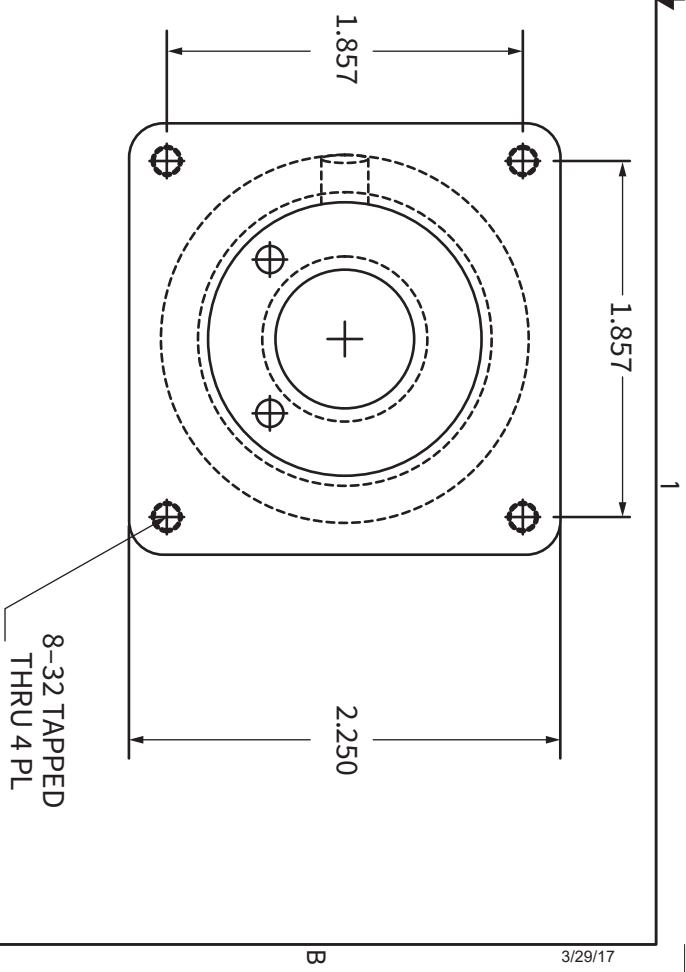
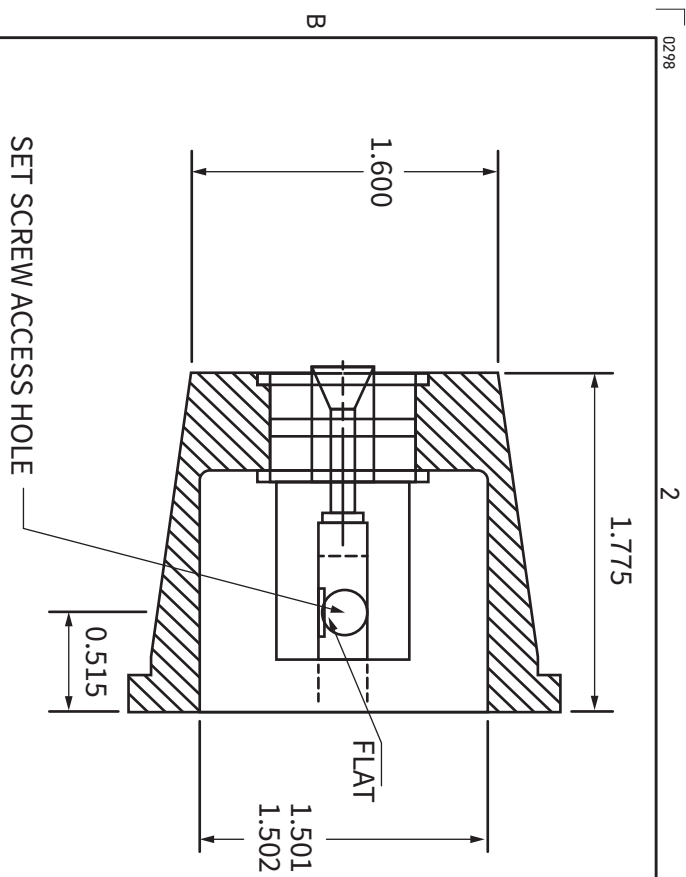

Figure 1—Components of the stepper motor and mount. The motor can also be mounted with the electronic cable facing downward.



If using a non-Sherline stepper motor, make sure to grind flats on the shafts as shown where the coupling and handwheel set screws contact the shaft.

Mounting Instructions

To mount the motor, start by turning the lead screw until the coupling set screw lines up with the access hole in the mount. Carefully insert the motor shaft into the coupling. With the flanges touching, rotate the stepper motor until the flat on the shaft is in alignment with the coupling set screw. Tighten the set screw. Rotate the motor to align with the motor with the 8-32 tapped holes. We usually attach the motor using three screws and use a zip tie in the fourth hole to secure the wire bundle.

If you decide to use LocTite® on the shaft set screw, a problem can occur if the motor has to be removed. What can happen is the shaft ends up glued to the coupling. If this occurs, loosen the preload nut until the motor and shaft can be backed out to expose the coupling so you can work on it. Be careful not to flex the coupling or it can break at the dampening slots.

DO NOT SCALE DRAWING !!!
UNLESS OTHERWISE SPECIFIED
DIMENSIONS ARE IN INCHES.
TOLERANCES ARE:
DECIMALS .00 ±0.006
DECIMALS .000 ±0.003
ANGLES 1°
DEBURR HAND
HEAT TREAT NONE
FINISH BLACK ANODIZE

SHERLINE SHERLINE PRODUCTS, INC.
TITLE: **STEPPER MOTOR MOUNT**

DRAWN	JOE MARTIN	SCALE	1 = 1	SIZE	A	PART NUMBER	67102	REV.	1998-09
CHECKED	JOE MARTIN								
DESIGNER	JOE MARTIN	MATERIAL	3 5/16 ROUND 6061 T6			SHEET	1 of 1		



SHERLINE STEPPER MOTOR SPECIFICATIONS—NMB MOTORS

Sherline P/N:	67127 (w/ DIN plug and flats on shaft) 67130 (no plug, flats on shaft)
Manufacturer:	NMB (Minebea Co. Ltd.)
Mfg. P/N (Type):	23KM-K035-62V (double shaft)
Frame size:	NEMA #23
Step angle:	1.8°
Voltage:	3.2 V
Current:	2.0 A/Φ
Resistance:	1.6 Ω/Φ
Inductance:	3.6 mH/Φ
Holding torque:	9.7 kg-cm
Rotor inertia:	250 g-cm ²
Number of wire leads:	6 (See color code diagram FIG. 2)
Weight:	1.32 lb (0.6 Kg.)
Length:	2.13" (54 mm)
Shaft:	Double ended, 1/4" diameter

See figure 3 for the pin diagram and wire color layout of the stepper motor connector cables we supply with our stepper motors. Since there is no industry standard for wire colors in this field, if using a connector not supplied by Sherline each pin and color should be confirmed with a continuity tester before applying power.

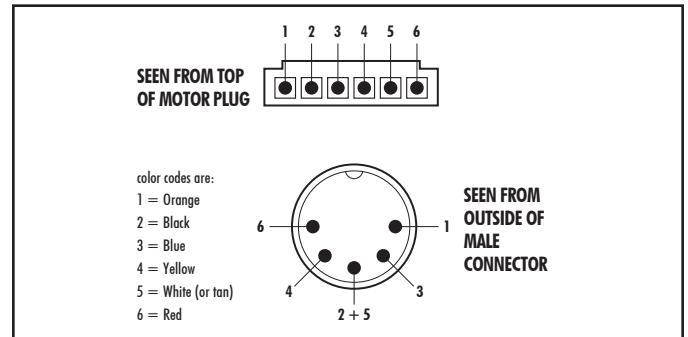

FIGURE 3: diagram shows which pin in the DIN connector is wired to which position in the motor connector.

NOTE: Motors can be wired in either unipolar or bipolar configuration depending on how the leads are connected. Sherline motors with plugs are wired for unipolar operation.

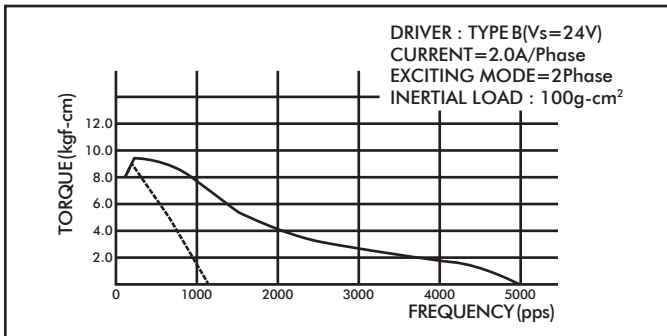

FIGURE 1—Motor torque curve

Lead Wire Connection and Color Code

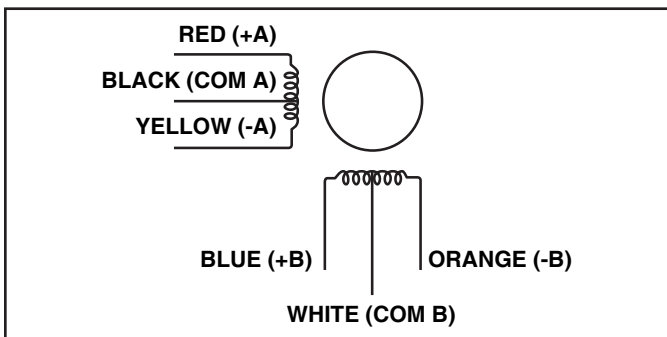

FIGURE 2— Color of internal wiring for NMB motors

PRECAUTIONS

- Make sure the ends of raw wires are not touching each other when turning the handwheel by hand to drive the stepper motor and leadscrew. It can cause the motor to feel rough and hard to turn.
- DC motors generate current when hand cranked that can damage the control unit. When positioning a stepper motor by hand using the handwheel, do not crank faster than about 1 rev/second. For long travels, use the jog mode of your CNC control software.
- Poor connections can cause arcing, which can burn out motors or control chips. Always make sure plugs and connections are fully engaged and making good contact.
- Always turn off driver box power before plugging in or unplugging a stepper motor.