

## TIP 4 — Drawbolt Washer Retainer/Steven Smith

---

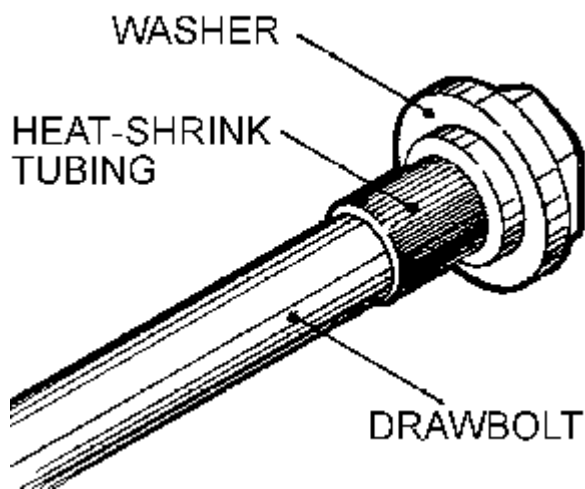

*Here's a simple and good looking way to keep a drawbolt and washer together.*

When you lift a drawbolt out of the mill spindle, the washer can easily slide down the bolt and fall off if you are not careful. The bolt and washer can also become separated while rolling around in your toolbox. If you don't like spending time looking under your workbench or in toolbox drawers for small parts, here is a tip from Steven Smith that solves the problem. He took a short length of heat-shrink tubing and slipped it over the 1/4" shaft of the drawbolt. If the fit is tight enough, you don't even need to heat it to keep it in place. If it fits loosely, just heat it with a match until it shrinks into place to act as a retainer for the washer. On a larger bolt, he also found that the rubber grip from a ball point pen worked to accomplish the same thing. In fact, any piece of tubing of the proper size will do the job. A few wraps of electrical tape will also work, but heat-shrink tubing is the neatest and most professional looking solution we've seen yet.

Our thanks go to Steven Smith of San Mateo, CA for this suggestion.

### **An alternate suggested by Alan Haisley:**

“Instead of heat-shrink tubing, which I didn't have in the size required, I obtained a small O-ring and found that it works nicely. This also makes it easy to either shift the amount of retainer play or disassemble the drawbolt and washer if desired.”

Alan Haisley, Lancaster, New York