

NOTICE!
This is a discontinued item. This item, and some of its parts, are no longer available.

SHERLINE PRODUCTS
INCORPORATED 1974

Slow-Speed Attachment

P/N 3059

NOTE: Slow-speed attachment is designed for use with SHERLINE machines manufactured prior to 4/93 that are equipped with an AC/DC motor. The DC motor and two-speed pulley system on the newer machines has sufficient torque at slow speeds to make this attachment unnecessary.

Older model Sherline machines came equipped with an electronic speed controller which permits varying the turning speed of the lathe from 200 to 2000 RPM. This speed range is adequate for most of the work that will be attempted on this machine. However, slower turning speeds may be desired when machining large diameter parts made of hard materials on the lathe. This is a worthwhile attachment for the lathe, especially when used with the spacer block kit to increase the lathe's turning capacity. This attachment may also be used with the milling machine to reduce cutter speeds when using large diameter or special purpose cutters.

The Sherline slow-speed attachment provides a belt and pulley arrangement that reduces spindle speed by a factor of 2.5 to 1 and increases the available torque by the same factor. The resulting speed range is 75 to 800 RPM.

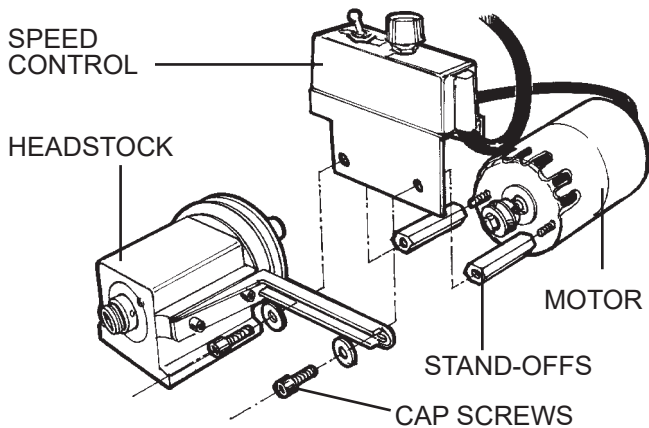

- STEP 1**
- A. Remove motor and speed control from headstock.
 - B. Remove two stand-offs from studs on motor.



- STEP 2**
- Remove, reverse and replace pulley on motor shaft.

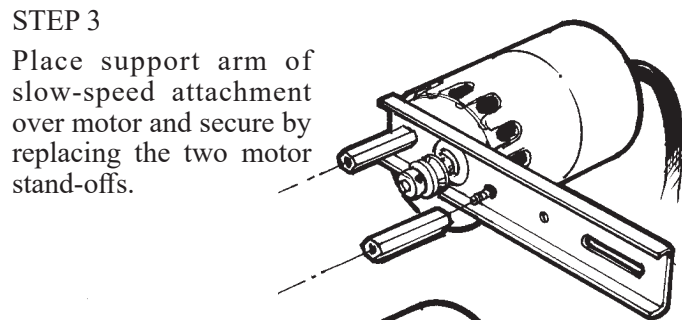

- STEP 3**
- Place support arm of slow-speed attachment over motor and secure by replacing the two motor stand-offs.

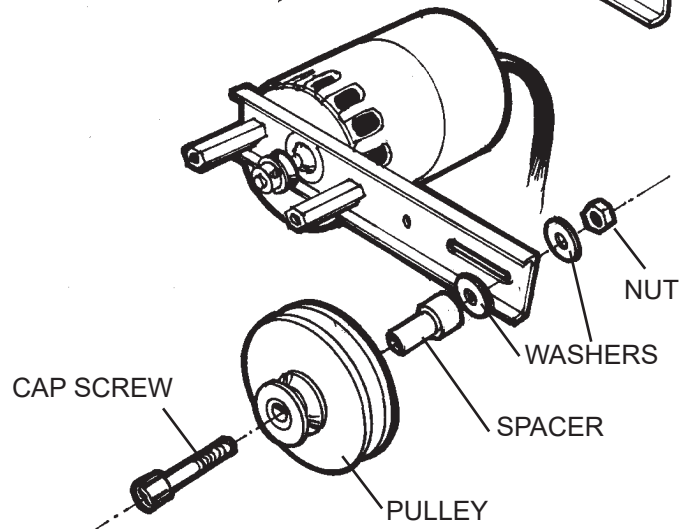

- STEP 4**
- A. Loosely attach the double drive pulley to the support arm. Position the SHORT drive belt over the pulleys. Check alignment of pulleys and relocate drive pulley on shaft if required.
 - B. Slide the double pulley to the outside until the belt is relatively tight and tighten the cap screw and nut to secure.

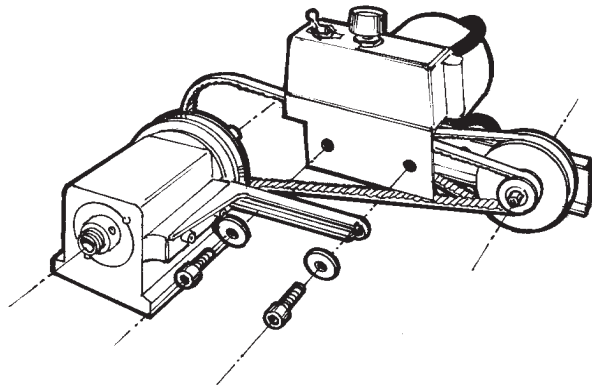

STEP 5

- A. Position the LONG drive belt around stand-offs and reinstall motor and speed control assembly onto the headstock. Do not tighten yet.
- B. Slip drive belt over pulleys. While applying tension on drive belt, tighten both cap screws into the motor stand-offs.

IMPORTANT!

BELT MUST NOT RUB HERE

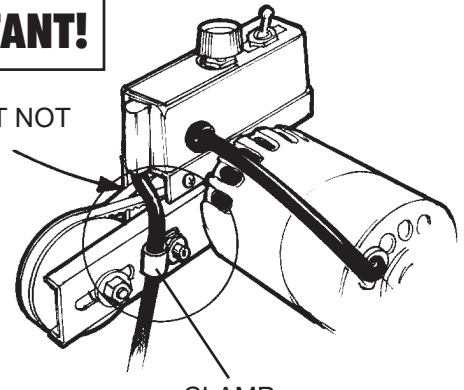

CLAMP

STEP 6

Be sure to use the clamp provided in the position shown to keep the power cord away from the drive belts.

Thank you,
Sherline Products Inc.

Parts List

NO. REQ.	PART NO.	DESCRIPTION
1	32040	Slow-speed Belt
1	32050*	Slow-speed Pulley
2	32060*	Slow-speed Bearing
1	32070*	Slow-speed Bracket
1	32080*	Wire Clamp
1	32090	1/4-20 Hex Nut
2	32100	10-32 Hex Nut
1	40510	10-32 x 3/8" SHC Screw
3	40660	#10 Washer
1	40720	10-32 x 1-1/2" SHC Screw
1	32150*	Slow-speed Pulley Shaft

* Indicates discontinued parts