

NOTE: Part Number 6101 is not included in Conversion set. It is an optional modification of your existing column. See explanation on next page.

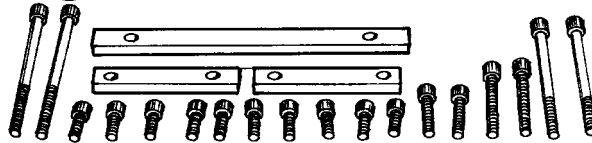

## Horizontal Milling Conversion P/N 6100

The horizontal milling conversion (P/N 6100) is a take-off of an idea sent to us by Joseph Kubin, a toolmaker from Maryland. With this attachment, the mill spindle (in the horizontal position) can be aligned with the X- and Y-axes. There are three places the column can be mounted to the horizontal conversion base. When the spindle is lined up with the Y-axis the outer most position is for drilling and milling (see Position "A").

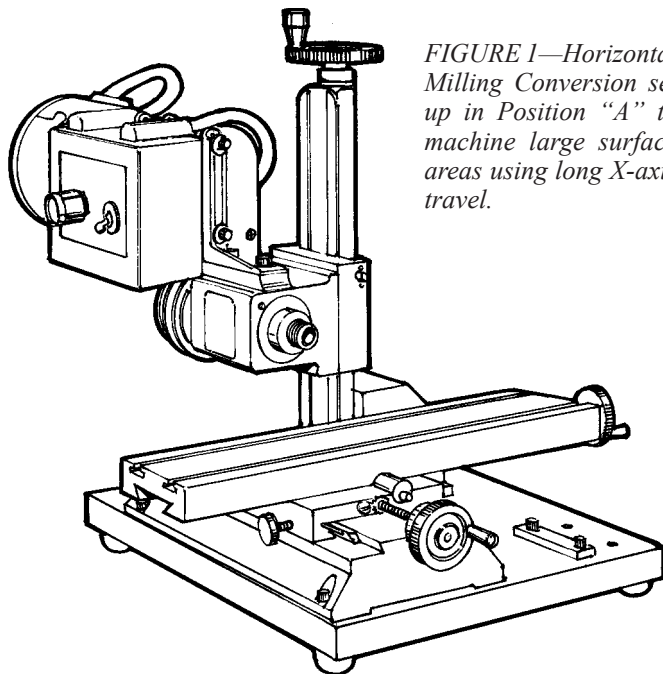

FIGURE 1—Horizontal Milling Conversion set up in Position "A" to machine large surface areas using long X-axis travel.

The closest position is used for milling. The configuration of the work has a lot to do with the choice to be made, but remember when milling, the closer the end mills are mounted to the spindle bearings, the more rigid the set up. The spindle can also be mounted lined up with the X-axis by reversing the "XY" table on the horizontal base and mounting the column in the single set of holes.

To configure the machine so the spindle is over the X-axis, the "XY" base must be reversed from its normal position,

that is, with the Y-axis handwheel away from the SHERLINE label (see Position "B").

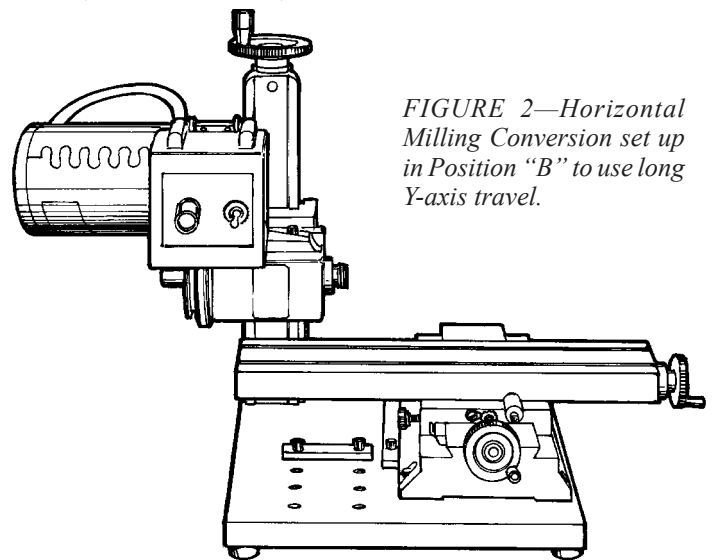

FIGURE 2—Horizontal Milling Conversion set up in Position "B" to use long Y-axis travel.

The advantage of this set up is you have 9" of throw from the spindle nose and you could drill and bore a hole 8" from the clamped down edge. If the mill was in its vertical configuration the same edge would interfere with the column. A point to consider is that any axis that moves the work in and out from the end of the spindle becomes the Z-axis and the up and down of the column will usually be called the Y-axis when the mill is in a horizontal configuration.

The 1/4" x 1/2" alignment bars are clamped against the column base and "XY" table after the machine is aligned so it isn't necessary to align it every time the configuration is changed. How close the machine has to be aligned is dependent on the work to be performed. A machinist square from the milling table to the column bed (dovetail) will usually be good enough, but a dial indicator would be helpful for close tolerance work.

It is possible to move the Y-axis saddle to the point the lead screw will disengage from the nut without the column being in place (normally, it would hit the column base before it could disengage).

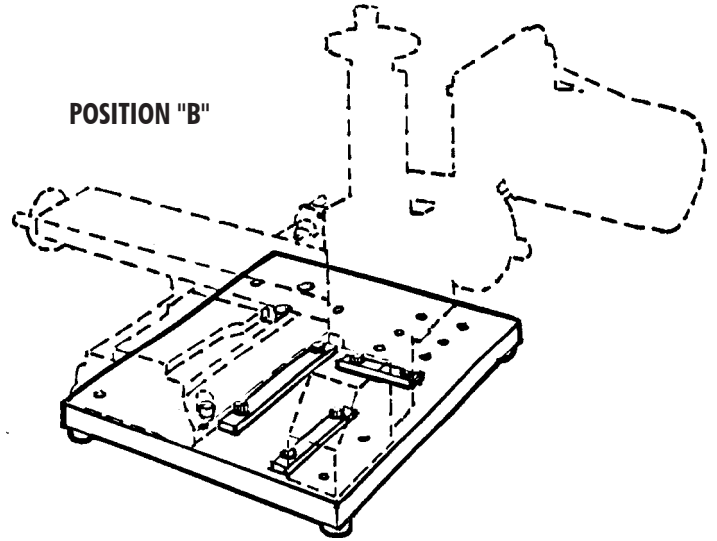
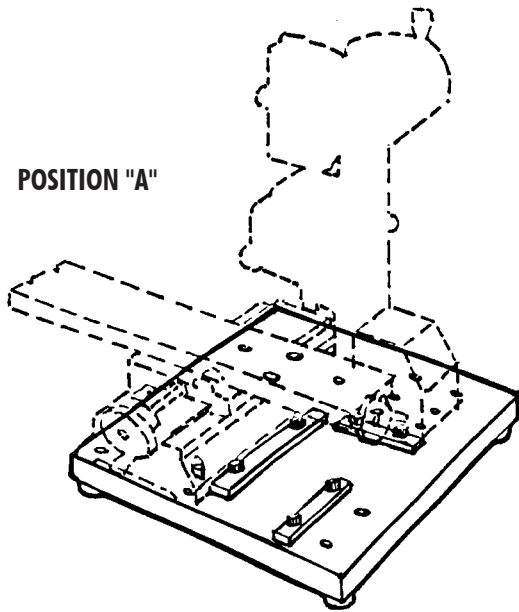

FIGURE 3—Shows suggested position of Mill and alignment bars mounted to Milling Conversion Table for each position. Note that in Position “A”, the vertical column and drive can also be mounted further toward the back of the table should your set-up require it.

The advantage of modifying the column (P/N 6101) for this attachment is to allow the spindle center to go below the top of the table. This allows a piece of material to be clamped directly to the table and machine the edge overhanging the table. We also modify the column saddle with another alignment groove in the horizontal position. All vertical milling machines manufactured after 1991 will come with the groove cut. The column base is modified by cutting 2" off and making it a spacer block and retapping what's left over. This allows the column to be mounted with or without the spacer in either the horizontal or vertical configuration. If you have access to a saw and mill, you could make these modifications yourself. The drawings are included for these modifications.

A part held vertical with the right angle plate can have a 9" x 6" area that can be machined without moving the work. If you think about it, that's a lot of movement for a machine of this size.

We believe you will find this a useful accessory. The right angle plate (P/N 3701) will also be very useful with the horizontal milling conversion.

#### Clamping instructions

To clamp the column to the horizontal milling conversion plate, use the 1" x 1/4-20 socket head cap screw (SHCS)-(2 included)—use the 3" x 1/4-20 SHCS (2 included) when the spacer block is used.

To clamp the column to the “XY” base, use the 1-3/4" x 1/4-20 SHCS (2 included). Use the 3-3/4" x 1/4-20 SHCS (2 included) when the spacer block is used.

The alignment bars and the “XY” table are held to the base with 5/8" x 1/4-20 SHCS (10 included).

Thank you,  
Sherline Products Inc.

#### Horizontal Milling Conversion (P/N 6100) Replacement Parts List

NO. REQ.	PART NO.	DESCRIPTION
1	4056	3/16" Hex key
2	5022	1-3/4" X 1/4-20 SHC Screw
1	6102	Horizontal Mill Base
1	6103	6.3" Alignment Bar
2	6104	2.8" Alignment Bars
4	6110	Rubber Feet with 1/2" x10-32 SHC Screws
10	6111	5/8" x 1/4-20 SHC Screws
2	6112	1" x 1/4-20 SHC Screws
2	6113	3" x 1/4-20 SHC Screws
2	6114	3-3/4" x 1/4-20 SHC Screws
1	6115	Horizontal Milling Instructions