

## Power Cord Conversion

### USA (117VAC) to European (240VAC) Plug

The speed control electronics used on the SHERLINE Lathe or Milling Machine will run properly on 240 VAC or 117 VAC, 50 Hz. or 60 Hz.\* The electronic circuit automatically senses the incoming current and switches as needed to provide 90 VDC to the motor.

The machines are supplied with a USA type plug but can be easily rewired to accept a European or UK type plug by attaching the wires using the color codes provided.

**\*NOTE:** A small number of the first DC powered machines produced had electronic speed controllers that were set up for 120 (117) volt use only and cannot be converted to use with 240 volt current. Before making a conversion, check the product label located on the aluminum frame of the speed controller to be sure you have a 117V/240V model. Early models had a small metallic label on the top of the frame which says in part, "Input Volts: 120VAC." Later models have a paper label on the front of the frame which reads, "KBLC-240DS." Only units with the 240DS designation should be converted to 240 volt use.

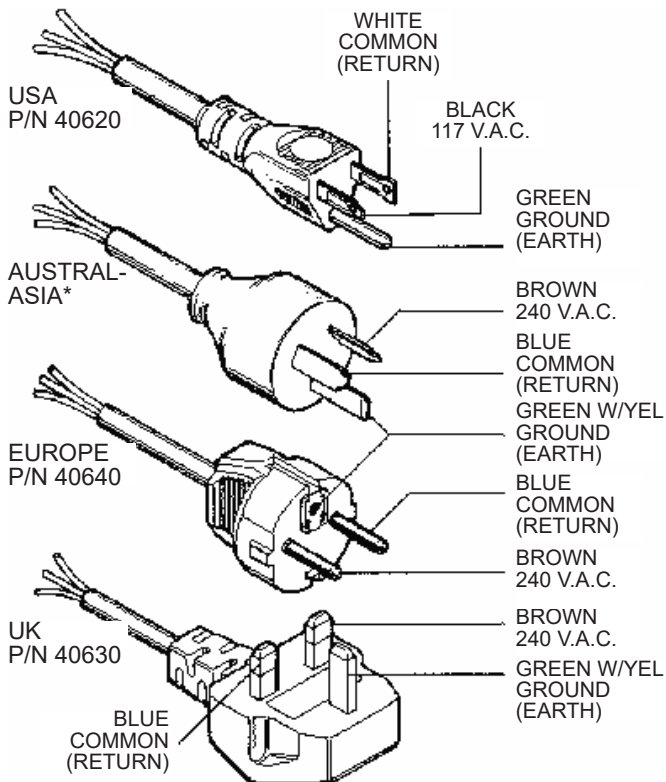

FIGURE 1—Types of plugs (\*Sherline does not supply the Austral-Asia plug).

### Wire Color Codes

WIRE	USA	AUSTRAL-ASIA	EUROPE	UK
117V/240V	Black	Brown	Brown	Brown
Common	White	Blue	Blue	Blue
Ground (Earth)	Green	Green w/ Yellow	Green w/ Yellow	Green w/ Yellow

**NOTE:** Early Sherline DC motors cannot be run on voltage other than 110-120 VAC!

The diagram below shows how to identify speed control modules that can and cannot be used with any voltage world wide.

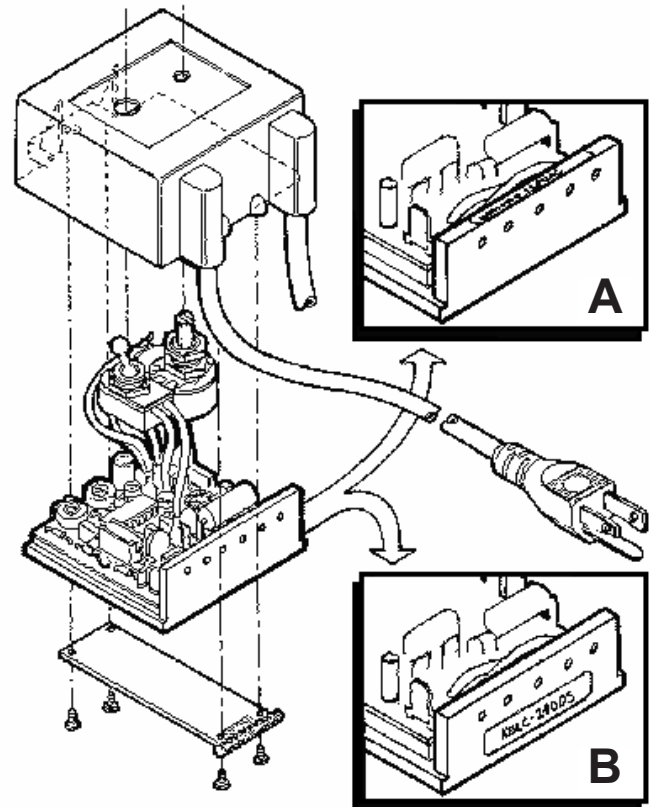

FIGURE 2A—EARLY MODEL: Small metallic label on top of Speed Control Frame lists input voltage as 120VAC. DO NOT ATTEMPT TO CONVERT TO 240 VOLT USE!

FIGURE 2B—CURRENT MODEL: Paper label on end of Speed Control Frame lists Model Number as "KBLC-240DS". This model may be safely converted for use with 240 volt current.