

**SHERLINE  
PRODUCTS**

INCORPORATED 1974

## 3.5" Lathe Thread Cutting Attachment

P/N 3100

### Purpose of the Thread Cutting Attachment

One of the big advantages of having a lathe is that it gives you the ability to cut threads. In reality you do not normally cut threads on a manual lathe if they could be done with low cost taps and dies. The reason you cut threads is to produce non-standard threads for which you don't have taps and dies. The second important reason is to produce a thread that is true or concentric with the centerline of the part. If we put threads on the Sherline spindles and chucks with taps and dies it would be impossible to produce 10% of our tools with acceptable runout. You will also find that when you start designing and building special parts you'll often need to use non-standard threads to work within the constraints of your design. For example, if you needed a 0.900" diameter, 24 TPI (threads per inch) thread, a tap and die could cost more than your lathe and take weeks to order.

Sherline offers a unique and versatile thread cutting attachment for its lathe. This low cost attachment enables you to machine 46 different unified thread pitches (Pitch range from 80 to 5 threads per inch) and 28 different metric thread pitches (Pitch range from .25 to 2.0mm). What's more, it allows you to cut them as either left hand or right hand threads. Ten optional gears with odd tooth counts are available for even more pitches. The lathe tool can, of course, be ground to cut any of the various thread forms, and any of these various pitches or thread forms can be cut on any pitch diameter you desire. This versatility enables you to machine any standard or non-standard thread you might desire as long as it is within the size limitations of the lathe.

The attachment consists of 15 hobbled metal gears, mounting bracket, engagement mechanism and 4.00" (102 mm) handwheel. Threads are generated on the Sherline lathe by gearing the spindle to the lead screw. As the spindle is rotated with the handwheel mounted on the headstock spindle, the tool will advance an amount equal to the ratio of the gears. When the tool has completed its movement, you simply stop cranking, back up the tool and turn the spindle in the opposite direction until the tool is past its starting point, reset the tool and you're ready for the next pass. It's as simple as tapping! By using a 127-tooth gear (supplied), true metric threads can be cut on an inch lathe (Model 4000, 4400 or 4500) or true inch threads can be cut on a metric lathe (Models 4100, 4410 or 4530).

### An Introduction to Thread Cutting in the Real World

After designing and putting the enclosed screw cutting attachment into production, I sat down and started reading what other people had written about cutting screw threads before writing my own instructions. It amazed me that I had been able to cut threads all these years knowing so little. How and why I was able to do this is going to be the subject of my instructions. There are plenty of books available at any library to go into additional detail on the subject if required, but my instructions are based on using sharp pointed 60° tools and cutting threads for your own use.

The reason other books go into such great detail on the precise methods used commercially is that they are telling you how to cut threads from specifications for other people. They must have exact methods and standards to make sure that a bolt made in California will screw into a nut manufactured in New York. Fortunately, we have the tremendous advantage of having both pieces at hand and we can just "keep cutting 'till they fit." It's as simple as that! You simply select the proper gears from the chart; put in a 60° threading tool and have at it.

A point to ponder about thread cutting is how a lathe produces a thread. It doesn't matter whether it is a 20" or a 3" lathe. The principle is the same. The leadscrew that drives the saddle is geared directly to the spindle. When the spindle turns, the saddle moves. If they were geared one to one, the pitch cut would be the same as the pitch of the lead screw. On Sherline's 3.5" lathe, this would be 20 Threads Per Inch (TPI). If we turned the lead screw 180° while we turned the spindle 360° (by using a 20 tooth to a 40 tooth gear arrangement) we would cut 40 TPI. Please note that we did not have to consider the diameter of the stock. The only requirement is that the major diameter is at least twice the depth of the thread plus enough material to support these threads while cutting them. One gets used to hearing a diameter called out with the threads, such as 1/4-20, 6-32, 10-24, etcetera, but while it's unusual to think of 40 threads per inch cut on something 2" in diameter, in some cases it may be entirely practicable to do so.

It may interest you to know how a metric thread can be cut on a 3" lathe that has American National screw threads on its leadscrew. The 127-tooth conversion gear does this by driving the leadscrew at a ratio that converts 20 TPI to 1 mm. Consider 100T on the spindle driving a 127T. The

ratio is .7874 to 1. The leadscrew has 20 TPI:  $.050" P \times .7874 = .03937" = 1 \text{ mm}$ .

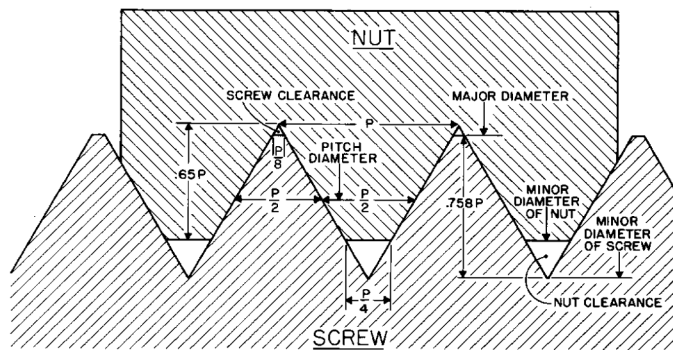

Figure 1—Component parts of a thread cut with a sharp pointed 60° Vee tool.

- MAJOR DIAMETER— Largest diameter of the thread of either the screw or the nut.
- MINOR DIAMETER— Smallest diameter of the thread of either the screw or the nut.
- PITCH DIAMETER— The theoretical diameter that falls on a point where the thread width and the groove width are the same.
- PITCH (P)— The distance from point to point measured parallel to the axis. Metric threads are always expressed in Pitch
- LEAD— The distance a screw thread advances axially in one turn. On a double lead screw, the lead is twice the pitch.

**NOTE:** The same methods can be used in figuring dimensions for American (inch) or Metric screw threads.

$$1 \text{ mm} = .03937"$$

$$\text{Pitch (Metric)} \times .03937" \times .758 = \text{depth of screw thread in inches}$$

Take the time to familiarize yourself with component parts of the screw thread from Figure 1. The pitch diameter is the important one to consider. Before going on, let's take the time to really understand why. The pitch diameter determines how a screw or thread will fit, not the major diameter. Suppose you were cutting 20 TPI and the major diameter was .010" undersized and the pitch diameter was correct. About the only thing wrong would be that the flat on the point of the thread would be a little wide, but it would still have approximately 75% of its strength and work well.

Now let us suppose we cut the pitch diameter undersized by .010". We would end up with a nut that fits so loose and a thread that was so weak that we would have to scrap it. This is where "cutting to fit" comes in. You can compensate for some pretty bad errors on the major and minor diameters by having the pitch diameter correct. To get it correct, all you have to do is to keep trying it for size as you cut. Don't ever take the part out of the chuck to try it because it would be next to impossible to re-chuck it in exactly the same place. However, the entire chuck, along with the part, could be removed from the lathe to try it for

size. Don't force anything when trying the part for size, because you might move the part slightly in the chuck, and really "screw things up."

Why have I made such a point about having the major or minor diameter wrong and still making the part work? Read on. You're probably thinking I must really be a "hacker" if I can't cut a diameter within .010". Well, the problem in many cases, is not how close you can cut to a diameter, but what the diameter should be.

Example: Your buddy just heard you bought a nice, shiny new lathe complete with a screw cutting attachment, and like all good friends he immediately goes to work trying to figure out how you and your new lathe will be of some use to him. It doesn't take him long! He has a camera that he tried to repair himself last year, but lost an important part. Of course the missing part has metric threads, but that's a "snap" for a Sherline lathe. A quick check with a thread gauge indicates that it has 0.9 mm Pitch. No problem, yet. It is an internal thread, so you will have to cut a screw to mate with it. Here's the problem: What is the major diameter? You can measure the diameter of the hole, but you can't be assured that the thread form is perfect and that this is really the minor diameter. You can only assume that it's close. Now take this dimension and add to it twice the depth of the thread, which should give you the major diameter. To get the depth of one thread, multiply the Pitch x .6. (Note: Pitch x 1.2 + Minor Diameter = Major Diameter). Total depth of thread using a sharp pointed 60° tool =  $P \times .65 = .036" \times .65 = .023"$ .

The constant .6 is not used to figure depth of an external thread, it is just one used to get you in the "ball park" in a situation such as this.

At least we have a fairly reliable place to start now and can probably get one cut that will work on the first try. Always keep track of the total depth of cut in case it comes out undersized. At least you'll know how deep not to cut it on the second one!

The example I gave you was one of the more difficult situations you may run into, not only because you had to do the job for free to keep a friend, but also because you had very limited information from which to work.

Usually, you will be cutting both the screw and nut. This is a case where two wrongs can almost equal one right. You can rectify any error you may have made in cutting the first one by compensating for it in the mating part.

Left-hand threads can be cut as easily as right-hand threads on a lathe; the only difference being the addition of an idler gear that reverses tool movement so that it travels left to right instead of right to left.

It's hard to appreciate just how much money an inexpensive lathe like this with a screw cutting attachment can save you until you have had to have a special part made that doesn't have a standard thread size. Even though there may be taps or dies available, a single left-hand 1-32 set would probably cost half as much as your entire thread cutting attachment.

What I have tried to do in these opening remarks is to show that screw cutting is really easy, and to give you the self-confidence it takes to do any job well. Too often, good craftsmen are stopped from venturing forth because the only information available shows the technically perfect way to do things rather than the simple, practical methods everyone really uses.

### Thread Cutting Conversion Kit

This kit has been engineered to add additional versatility to your lathe. With this attachment, a wide variety of threads, both right-handed and left-handed can be produced. Most American standard and metric threads may be cut with equal ease and precision. The accompanying charts list the entire range from which you may choose. (See Figure 5.)

#### Conversion Instructions (Refer also to Illustrations)

1. Carefully drive the furnished small sheet metal screw into the hole located in the spindle that extends from the left side of the drive pulleys. Use a proper size screwdriver for this operation and avoid installing the screw at an angle since it must seat squarely against the spindle. After driving, remove the screw and dress down any "burr" that is raised around the edge of the hole. A small, fine file is suitable for this. Next, slide two thin spacer washers over the tube and against the pulley. Reinsert the sheet metal screw and tighten firmly.
2. Remove the headstock. Locate the exposed flat head socket screw in the top of the bed a loosen it a few turns.
3. From below, remove the cap screw under the base directly below headstock. Note how many washers (if any) are used with this screw. (Normally a 4000-series lathe does not require any washers and a 4400-series lathe uses one washer.)
4. Grease the sliding shaft with the flats on both ends and slide it into the leadscrew support (situated directly below the pulley). Be sure the end with the small flat enters first. Now slide the fixed shaft with a single flat into the leadscrew support. To guarantee that the shaft is fully inserted and engaged, rotate it one or two revolutions while applying gentle inward pressure to

the end of the shaft.

5. Replace the screw from Step 3, making sure that the point of the screw goes into the machined groove in the shaft. Make sure also that any washers that were on this screw are still in place. Check that the shaft is free to rotate. If the shaft binds, first double check to assure that the end of the cap screw is registered in the groove of the fixed shaft and then add an extra washer under the screw head if needed so it doesn't go in quite as deep. Retighten the flat head socket screw in the bed and replace the headstock.
6. Pull out the black plug on the front of the lathe base below the name plate and slide the remaining shaft (with handle) into the hole with the handle facing upward. It may be necessary to rotate the shaft about 30° each way to get it to completely seat and register with the sliding shaft.

**NOTE:** If insertion or movement of the engagement lever is difficult, try loosening the two screws on the bottom of the machine that hold the bed to the base. Move the bed slightly until a good fit occurs.

7. It may be necessary to deburr parts for smooth operation.

**NOTE:** The section below entitled "Cutting A Thread for Practice" uses the example of cutting a 28 pitch right-hand thread on a 1/4" diameter piece of stock. The following numbers are based on that setup.

#### Example: Setting up to Cut a Typical Thread

Refer to the chart (Figure 5) and select the type of thread to be cut. As an example, we have chosen an American standard, 28 TPI, right-hand lead.

Figure 3

Setup for cutting 28 Threads Per Inch

GEAR	A	B	C	D	E
TEETH	100	100	20	28	40

**NOTE:** Idler gear "E" is used for right-hand threads, idler gears "F" and "G" are used for left-hand threads and are, therefore, not used in this example.

Remove the motor assembly by removing the two socket head cap screws that secure the motor mounting bracket to the headstock and slip the drive belt off the pulley. (See the Assembly and Instruction Guide that came with your machine for more details if needed.)

Slide gear "A" (100) onto the spindle engaging slot with the previously installed sheet metal screw head.

Install gear "B" (100) and gear "C" (20) onto the primary support arm. The drive pin is used not only to drive the "C" gear, but also to hold the "B" gear on the arm.

Install gear "E" (40) on the secondary support arm.

Slide the lower split end of the primary support arm over the leadscrew support. Adjust until gear "B" meshes properly with gear "A" (100). When mesh is satisfactory, tighten clamp screw.

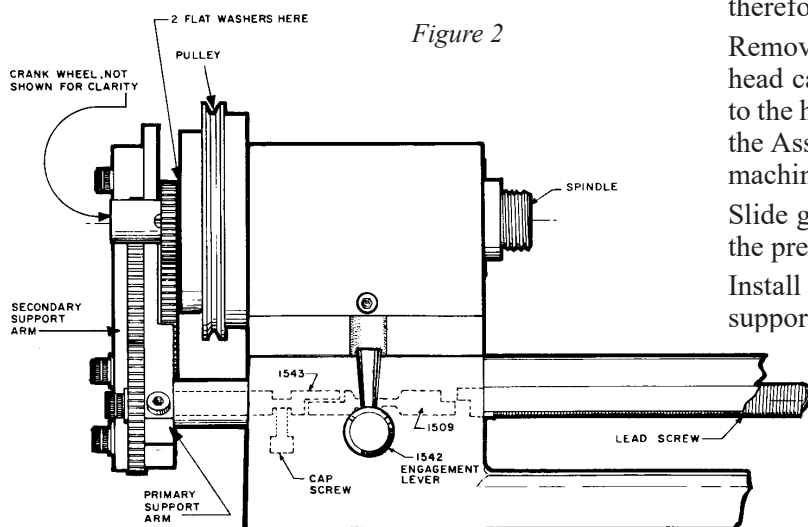

Figure 2

Side view, thread cutting attachment installed

Install gear “D” (28) and secure with a hex head screw and small washer. NOTE: This screw only needs to be finger tight and should not be used when it interferes with the secondary support arm. Adjust the secondary support arm and gear for proper engagement with the mating gears. When satisfactory, tighten the retaining screw and pivot screw.

Install the crank wheel by it sliding it over the spindle.

Line up the slot with the protruding sheet metal screw head and tighten down the crank wheel set screw using a hex wrench. A few drops of oil on moving parts will be helpful.

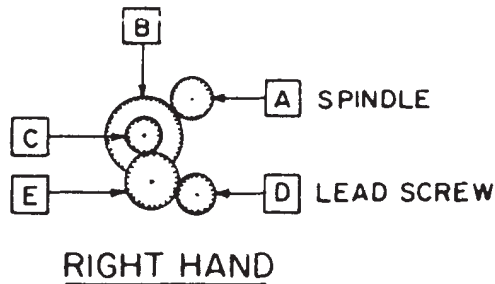

Figure 4—Gear Setup Diagram for Example. NOTE: See Figure 7 on page 8 for a detailed setup drawing.

### Cutting a Thread for Practice

I believe the time has come to “HAVE AT IT.” We will start by chucking up a piece of aluminum and turning it to 1/4" diameter. Let’s cut 28 TPI on it. Be sure to have a nut to check it with. Looking at the chart we see we need a gear “A” (100T) on the spindle, driving a gear “B” (100T), that is attached to the gear “C” (20T), driving the lead screw gear “D” (28T), using the idler gear “E” (40T) that mounts on the swing arm. The gears should mesh so they run “free” and have a reasonable amount of backlash. NOTE: All gear trains have some “backlash” and it will not affect the quality of the thread, but it does have to be allowed for. This is why the tool has to be backed out before the lathe spindle is reversed.

Over 90% of the threads cut on a lathe of this type will have a pitch less than .070, and be less than 3/8" long. Now and then you may have to cut a fairly course thread (more than .070" pitch), and it is a good idea to “rough out” the thread by moving the tool post slightly to the left between passes. This keeps the tool from having to cut on both sides of the thread at the same time. On a standard lathe, the tool is advanced by the compound rest which is set at 29°. This allows only one side of the tool to cut and lessens the load considerably. The final cut is then taken with the crossslide being advanced to “clean up” the thread. We can get the same effect by moving the tool post. When cutting fine threads you can get away with cutting “straight in”. The crank drive gives you the “feel” and a precise method of stopping needed in single-pointing fine threads. Cranking the spindle counter-clockwise gives you reverse. This allows you to cut the entire thread without disengaging the leadscrew.

Establish the depth of the first cut by bringing the tool in to the point where it just touches the part surface. Write down the dial setting. Now engage the leadscrew lever. The leadscrew may have to be turned back and forth a little while

applying slight pressure on the lever in order to get it to engage properly. **DO NOT DISENGAGE THE LEVER UNTIL THE THREAD HAS BEEN COMPLETELY CUT.** With the tool moved past the end of the part, advance the tool inward .003" for first cut. Turn the spindle counter-clockwise until the desired length of thread has been cut. Back the tool out until it is completely clear of the part. Crank the spindle clockwise until the tool is at the original starting point. Advance the tool to its last point plus .002". I’ve always found it useful to write these dial settings down too. It is amazing how fast you can forget one! Now take the second pass by cranking the spindle counter-clockwise. The amount the tool should be advanced from this point on should be governed by the amount of force it took the last pass. The cut will get progressively heavier each time the tool is advanced. Remember, you can’t ruin your part by taking too light a cut. To figure what the total amount the tool should be advanced if you are using a sharp “vee” form tool (standard form of tool used in single pointing threads) simply multiply the pitch times .758.

Example: Pitch of 28 TPI = 1/28

$$\text{Pointed tool depth} = P \times .758 = 1/28 \times .758 = .027$$

If you are not too good with math and don’t like to do it, just keep cutting and looking at the flat on the top of the thread. When the flat is 1/8 the pitch, the nut should fit. Either way, check it long before you think it is finished to be on the safe side until more experience is gained. The last two passes should be repeats of previous dial settings to clean up threads. Not too hard was it? No matter what type of threads you may cut, the basic method will remain the same.

### Cutting Internal Threads

Internal threads are very seldom cut full depth. To figure the hole size you should start with, take the pitch of thread you are cutting and multiply it by 1.083. Then subtract the resulting number from the major diameter. To figure the total depth using a sharp pointed 60° tool, multiply the pitch by .65.

EXAMPLE: To cut an internal 1.5-28 TPI:

$$\text{Major Diameter} = 1.5''$$

$$P = 1/28 = .036''$$

$$\text{Major Diameter} - (P \times 1.083) = \text{Hole Size}$$

$$1.500'' - (.036'' \times 1.083) = \text{Hole Size}$$

$$1.500'' - .039 = 1.461''$$

$$\text{Hole size} = 1.461''$$

### Cutting Double Lead Pitches

A double lead thread could be cut by picking change gears that are one-half the pitch and indexing the “A” gear 180° after cutting the first thread to depth. NOTE: There isn’t any way to check a double lead until it is completely cut, therefore, the depth must be figured mathematically. It has always been fun for me to do jobs like this, not necessarily because they were needed, but just to see if I could do it!

### **Screw Cutting Operation Review**

(Read detailed instructions before proceeding.)

1. Turn or bore stock to proper diameter.
2. Remove the motor assembly from the lathe by unscrewing the two socket head cap screws that hold the motor bracket to the headstock.
3. Install the 60° brazed tip carbide thread cutting tool in the tool post.
4. Place the tool bit at the starting point of the thread and set it for a .003" depth of cut.
5. Engage the lever at the base of the lathe by turning the handle clockwise. Turn lead screw handwheel back and forth slightly until full engagement occurs.
6. Turn the spindle crank handwheel until the tool bit has traveled the full length of your intended thread.
7. Back the crossslide out to clear the tool from the thread.
8. Turn the crank handwheel backwards until the tool bit has traveled past the starting point of the thread.
9. Return the crossslide to its original position and advance it an additional.002" in depth.
10. Repeat steps 6, 7, 8, and 9 until the full thread depth has been cut. Using cutting oil will make cutting easier and will give a better finish.

#### **Notes Regarding Using the Threading Attachment with a Digital Readout**

To keep the drive gear from scratching the tachometer decal on your pulley, make sure the shim washers (P/N 31050) are in place to space the shaft gear away from the pulley. Then adjust the drive gear so that it is centered or slightly off-center away from the pulley so that it can't contact the decal. As an alternative, a piece of thin steel shim stock could be cut like a large washer and inserted between the gear and the pulley for protection.

Note also that the addition of DRO handwheels to your lathe will cause the long leadscrew to be moved slightly to the right. This will require the use of a slightly longer sliding shaft when using either the thread cutting attachment or the P/N 3001/3011 power feed. When purchasing a DRO for use with a machine using either of these attachments, be sure to mention that you have these attachments. You will be supplied with a longer version of the P/N 15090 sliding. The longer shaft is P/N 81509 should you need to order it.

Thank you,  
Sherline Products Inc.

### **\*Notes on Cutting Certain Thread Pitches**

(Refers to chart on following page.)

Cutting left hand threads coarser than 20 T.P.I. and right hand threads pitch 5 through 9 T.P.I. will require that you remove the shaft from the 100-tooth gear and press it in to the 50-tooth gear. These are threads that wouldn't normally be cut on a machine of this size. If you don't wish to switch gears and shafts, an extra gear and shaft can be ordered from the replacement parts list to eliminate this problem.

On threads with pitches 5 through 9 T.P.I. you will encounter a problem with interference between the handwheel and the 40-tooth gear. A spacer should be made to keep the handwheel mounted out toward the end of the spindle to eliminate this interference. This also occurs when making a 1.0 mm pitch thread on the 4100 metric lathe.

#### **Coarse threads in steel**

Threads cut with a pitch coarser than 16 T.P.I. or 1.5mm begin to push the maximum capabilities of a small lathe when cut full depth into steel. You may have to slightly move the tool post occasionally so the entire thread form isn't being cut at one time. Pitches coarser than this can be cut into plastic and wood with no problems. Large pitch threads are also used with multiple lead threads. For example: a 20 T.P.I. double-lead thread would need a 10 T.P.I. setup and a cutting tool that would form a 20 T.P.I. thread form.

#### **Cutting Inch Threads on a Metric Lathe and Metric Threads on an Inch Lathe**

**INCH LATHES**—The chart on the next page assumes that you have an inch lathe. You can cut metric threads on your inch lathe by using the chart on the right side of the page.

**METRIC LATHES**—If you have a metric (P/N 4100 or 4410) lathe you will need to substitute a gear to use the chart. When cutting inch threads on a metric lathe, substitute a 127 tooth gear for the 100 tooth gear listed in column "A." (Note that you will only be able to cut threads from 5 TPI to 40 TPI.) When cutting metric threads on the metric lathe, substitute the 100 tooth gear for the 127 tooth gear listed in the column for gear "B."

NOTE: This chart lists gears used with the inch version of the lathe. For use with metric lathes see the note \*\* below the chart for alternate gearing.

**Figure 5—Gear Selection Chart for Thread Cutting Attachment**

THREADS PER IN.	INCH THREADS					Gear E used for RH threads only ▾		Gears F and G used for LH threads only	
	GEAR A	GEAR B	GEAR C	GEAR D	GEAR E	GEAR F	GEAR G		
80	50	100	20	40	38	28	22		
76	50	100	20	38	40	30	22		
72	50	100	20	36	40	28	34		
68	50	100	20	34	40	28	30		
64	50	100	20	32	40	28	30		
60	50	100	20	30	40	28	26		
56	50	100	20	28	40	26	30		
52	50	100	20	26	40	24	34		
48	50	100	20	24	40	26	30		
44	50	100	20	22	40	26	30		
40	100**	100	20	40	38	28	22		
39	100**	100	20	39*	40	28	22		
38	100**	100	20	38	40	30	22		
37	100**	100	20	37*	40	26	28		
36	100**	100	20	36	40	28	34		
35	100**	100	20	35*	40	28	26		
34	100**	100	20	34	40	28	30		
33	100**	100	20	33*	40	28	30		
32	100**	100	20	32	40	28	30		
31	100**	100	20	31*	40	28	26		
30	100**	100	20	30	40	28	26		
29	199**	100	20	29*	40	26	30		
28	100**	100	20	28	40	26	30		
27	100**	100	20	27*	40	26	30		
26	100**	100	20	26	40	24	30		
25	100**	100	20	25*	40	26	30		
24	100**	100	20	24	40	26	30		
23	100**	100	20	23*	40	26	30		
22	100**	100	20	22	40	26	30		
21	100**	100	20	21*	40	26	30		
20	100**	100	20	20	40	26	24		
19 RH	100**	100	40	38	30	--	--		
19 LH+	100**	50	20	38	--	30	22		
18 RH	100**	100	40	36	30	--	--		
18 LH+	100**	50	20	36	--	28	34		
17 RH	100**	100	40	34	30	--	--		
17 LH+	100**	50	20	34	--	28	30		
16 RH	100**	100	40	32	30	--	--		
16 LH+	100**	50	20	32	--	28	30		
15 RH	100**	100	40	30	32	--	--		
15 LH+	100**	50	20	30	--	28	26		
14 RH	100**	100	40	28	30	--	--		
14 LH+	100**	50	20	28	--	26	30		
13 RH	100**	100	40	26	30	--	--		
13 LH+	100**	50	20	26	--	24	30		
12 RH	100**	100	40	24	30	--	--		
12 LH+	100**	50	20	24	--	26	30		
11 RH	100**	100	40	22	30	--	--		
11 LH+	100**	50	20	22	--	26	30		
10 RH	100**	100	40	20	30	--	--		
10 LH+	100**	50	20	20	--	26	24		
9+	100**	50	40	36	30	--	--		
8+	100**	50	40	32	30	--	--		
7+	100**	50	40	28	30	--	--		
6+	100**	50	40	24	30	--	--		
5+	100**	50	40	20	30	--	--		

PITCH (mm)	METRIC THREADS					Gear E used for RH threads only ▾		Gears F and G used for LH threads only	
	GEAR A	GEAR B	GEAR C	GEAR D	GEAR E	GEAR F	GEAR G		
.25	50	127	20	40	30	28	22		
.3	50	127	24	40	30	26	22		
.35	50	127	28	40	30	26	22		
.4	50	127	32	40	30	24	22		
.45	50	127	36	40	30	20	22		
.5	100	127	20	40	30	28	22		
.55	100	127	22	40	30	28	20		
.6	100	127	24	40	30	28	22		
.65	100	127	26	40	30	28	22		
.7	100	127	28	40	30	26	22		
.75	100	127	30	40	28	24	22		
.8	100	127	32	40	30	24	22		
.85	100	127	34	40	30	20	22		
.9	100	127	36	40	30	20	22		
1.0 RH	50	127	40	20	30	--	--		
1.0 LH	100	127	20	20	--	26	24		
1.1	100	127	22	20	40	24	26		
1.2	100	127	24	20	40	22	26		
1.25	100	127	30	24	38	22	26		
1.3	100	127	26	20	40	22	24		
1.4	100	127	28	20	38	22	24		
1.5	100	127	30	20	38	20	26		
1.6	100	127	32	20	38	20	26		
1.7	100	127	34	20	38	20	22		
1.75	100	127	35*	20	38	20	22		
1.8	100	127	36	20	38	--	--		
1.9	100	127	38	20	36	--	--		
2.0	100	127	40	20	30	--	--		

\* Gears marked with an asterisk and highlighted in a grey box are not included in the standard set but can be purchased separately.

\*\*METRIC LATHES—To use this chart with the model 4100 or 4410 (metric) lathe, use a 100-tooth gear in place of the 127-tooth gear (“B” gear) when cutting metric threads and a 127-tooth gear in place of the 100-tooth (“A” gear) when cutting inch threads. Press the shaft out of the 127-tooth gear and into the 100-tooth gear. Inch threads finer than 40 T.P.I. cannot be cut on the metric lathe.

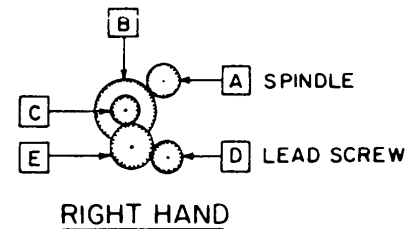

NOTE—Gear “E” or “F” and “G” are idler gears and are used to transmit power and control direction of rotation only. See drawings on page 7 for more detail of how gears are actually installed on the support arms.

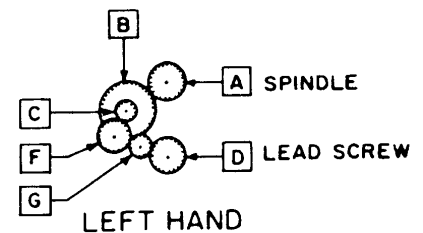

NOTE—When cutting right hand threads, Gear “E” is used in the vertical slot of the secondary support arm, part number 3103. When cutting left hand threads, gear “F” is used in the vertical slot and gear “G” is used in the horizontal slot and gear “E” is not used.

\* See notes on page 80 for cutting left hand threads with a pitch coarser than 20 T.P.I. and for cutting right hand threads with a pitch of 5 through 9 T.P.I.

Figure 6

**Exploded View**

**Thread Cutting Attachment**

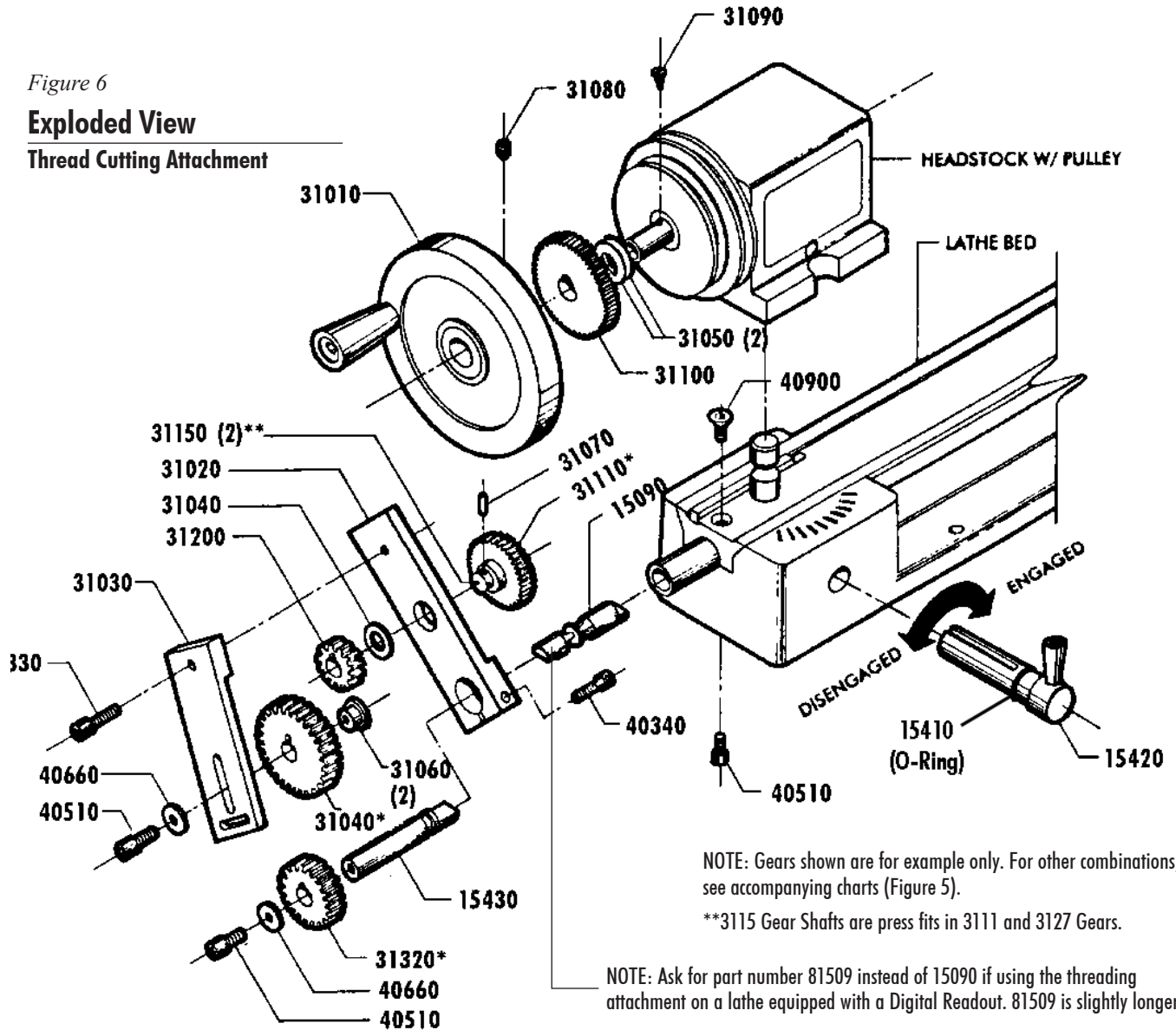

NOTE: Gears shown are for example only. For other combinations, see accompanying charts (Figure 5).

\*\*3115 Gear Shafts are press fits in 3111 and 3127 Gears.

NOTE: Ask for part number 81509 instead of 15090 if using the threading attachment on a lathe equipped with a Digital Readout. 81509 is slightly longer.

**Parts list, Thread Cutting Attachment**

NO. REQ.	PART NO.	DESCRIPTION	NO. REQ.	PART NO.	DESCRIPTION
1	31010	Handwheel	1	31260	26 Tooth Gear, 24 Pitch
1	31020	Primary Support Arm	1	31270	127 Tooth Gear, 56 Pitch
1	31030	Secondary Support Arm	1	31280	28 Tooth Gear, 24 Pitch
1	31040	Small Shim Washer	1	31300	30 Tooth Gear, 24 Pitch
2	31050	Large Shim Washer	1	31320	32 Tooth Gear, 24 Pitch
2	31060	Gear Bushing	1	31340	34 Tooth Gear, 24 Pitch
1	31070	Gear Drive Pin	1	31360	36 Tooth Gear, 24 Pitch
1	31080	10/32 X 3/8" Set Screw	1	31380	38 Tooth Gear, 24 Pitch
1	31090	Sheet Metal Screw, Pan Head, No. 6 X 3/16", Type A	1	31400	40 Tooth Gear, 24 Pitch
1	31100	100 Tooth Gear, 56 Pitch (W/ Notch)	1	31500	50 Tooth Gear, 56 Pitch
1	31110	100 Tooth Gear, 56 Pitch	1	15090	Sliding Shaft
1	40340	10-32 X 1" Skt Hd Cap Screw	1	15410	Sliding Shaft O-Ring
3	40510	10-32 X 3/8" Skt Hd Cap Screw	1	15420	Engagement Lever
1	40330	10-32 X 5/8" Skt Hd Cap Screw	1	15430	Fixed Shaft
1	40660	No. 10 Washer	1	40900	10-32 x 3/8" Flat Head Socket Screw
2	31150	Gear Shaft			
2	31200	20 Tooth Gear, 24 Pitch			
1	31220	22 Tooth Gear, 24 Pitch			
1	31240	24 Tooth Gear, 24 Pitch			

Optional 24 Pitch gears are available for cutting odd numbers of T.P.I., where the last two numbers before the final zero(s) in the part number represent the number of gear teeth. Available are sizes 31210, 31230, 31250, 312700, 31290, 31310, 31330, 31350, 31370 and 31390.

**Gear Installation on Primary and Secondary Shafts**  
*(Illustration shows gears for 20 TPI RH and LH setup)*

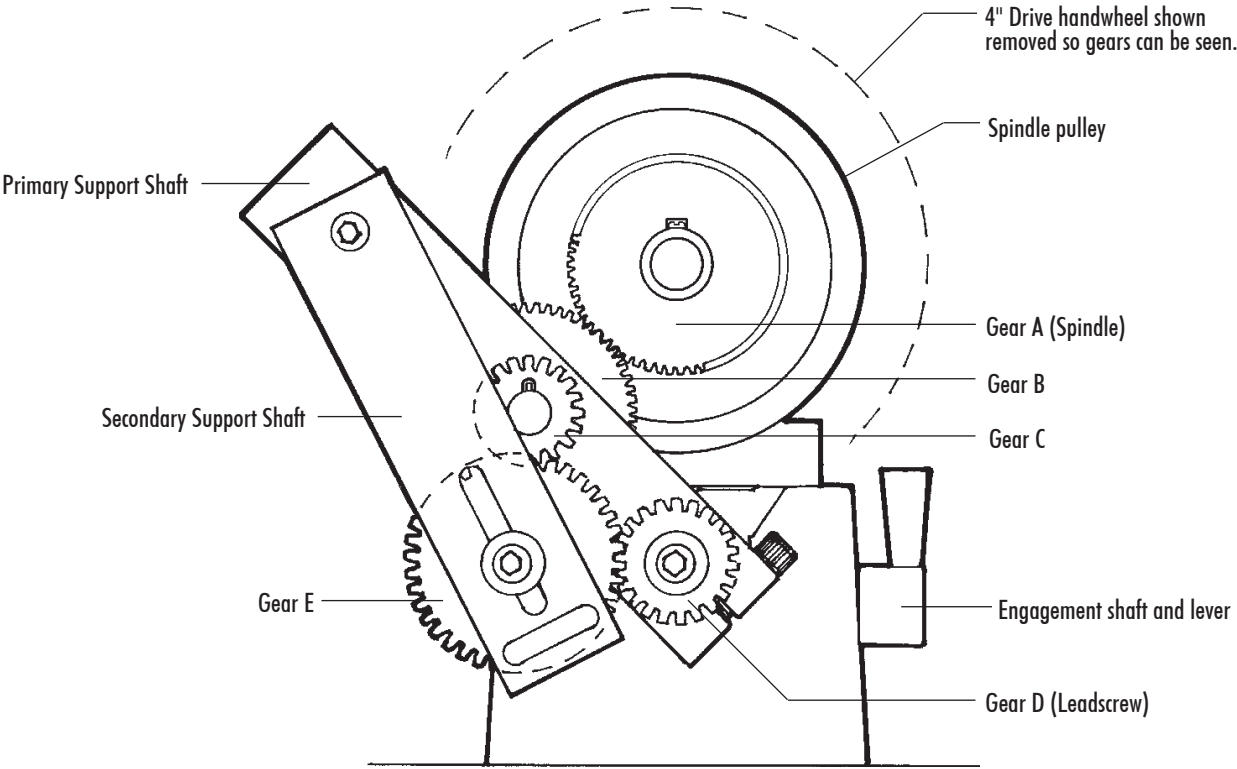

Figure 7a—Gears A, B, C, D and E installed for cutting a right-hand thread

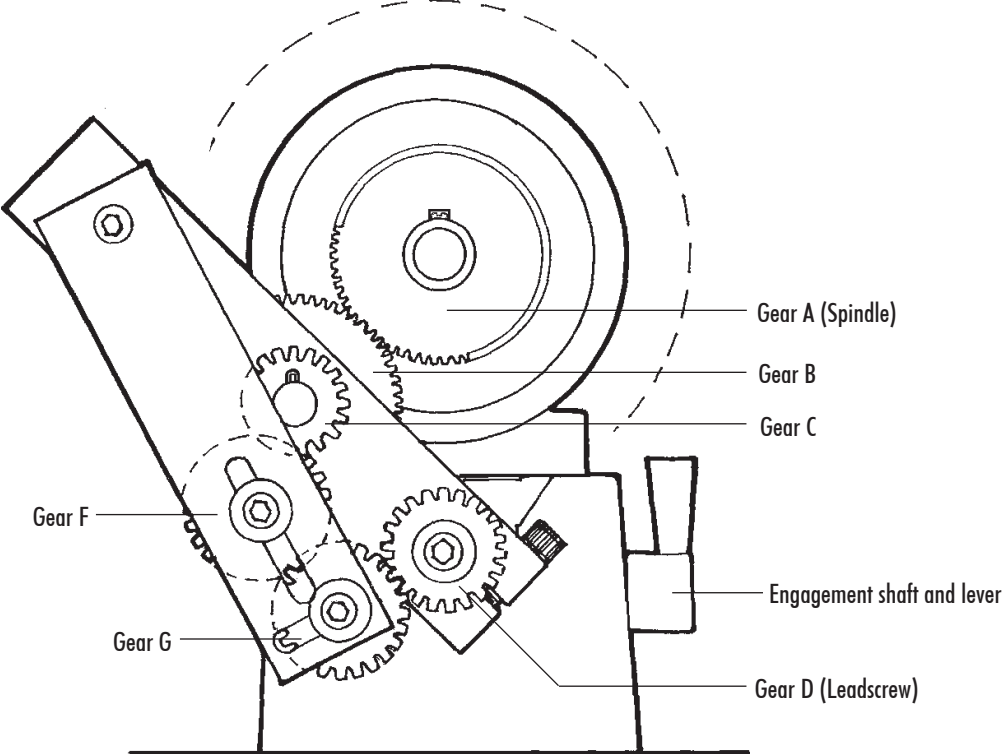

Figure 7b—Gears A, B, C, D, F and G installed for cutting a left-hand thread