

An optional third handwheel and encoder unit can be used on the vertical milling column to turn your lathe into a vertical milling machine with a 3-axis digital readout.

SHERLINE/WETTROTH 2-or 3-AXIS
Lathe Digital Readout
P/N 8200 (Metric P/N 8260)

The Digital Readout in the Modern Machine Shop

Digital readouts are popular on full size machine tools because they make the life of a machinist much simpler. They make it easier to accurately set or change the table position and eliminate errors caused by misreading handwheel increments or losing track of multiple rotations. Now that same convenience is available on tabletop size machines with the availability of a D.R.O. (Digital ReadOut) for Sherline lathes and mills. The compact electronics package and clever backlash compensation feature were designed by John Wettroth.

On industrial DRO's, a sensor reads a highly accurate external scale. On Sherline's DRO, the sensor reads rotation of the leadscrew. Because of the accuracy of Sherline's precision rolled leadscrew threads and the short travels on a machine of this size, this system makes it possible to provide a DRO with sufficient accuracy while maintaining a price appropriate for a machine of this size and cost.

The kit can be installed on any Sherline lathe, regardless of age and is very easy to use. Three axes of movement are provided so the readout can be used when the lathe is set up as a mill with the vertical milling column attachment. In the lathe configuration you will use only two of the three, as the tailstock spindle feed screw is not fitted with a readout. Remember that the directions of movement of the mill are referred to as the X-axis (table side-to-side),

Y-axis (table in-out) and Z-axis (spindle up-down) when seen from the leadscrew handwheel end of the lathe. When used as a lathe, the nomenclature changes slightly. The crossslide feed handwheel still controls what is called the "X" axis, but the leadscrew controls what is now called the "Z" axis. Remember also that as you feed the cutter into the rotating part with the crossslide handwheel you will reduce the diameter of the part by twice the amount of the feed. This is because you are reducing the part's radius but measuring its diameter. This DRO measures the change in *radius*.

The readout of any axis can be set to zero at any time with the push of a button. As you move the handwheels you can read the table position to three and a half decimal places on the digital readout. It is not necessary to keep track of the number of handwheel rotations to figure the stopping point on larger dimensions. This will be especially appreciated when cranking in "negative" amounts. Backlash is compensated for by setting it into the unit's electronic memory in increments of .0005". As a bonus, the package also includes an electronic readout of spindle RPM at all times.

Installing the D.R.O. Components on your Sherline Lathe

The following instructions describe the steps required to remove the existing handwheels and thrust collars and replace them with the D.R.O. encoder/handwheel units.

1. Move the crossslide all the way in. This will help locate the slide screw to assure that the collar is centered. The saddle can be positioned anywhere on the leadscrew.
2. If using a vertical milling column, raise the headstock all the way up to the top of its travel
3. Using a 3/32" hex wrench, remove the existing handwheels from the crossslide, leadscrew and vertical milling column by releasing their set screws and sliding them off their leadscrews. (If your lathe has resettable "zero" handwheels, loosen the collar locking knob and rotate the collar until the hole lines up with the set screw. Then use the 3/32" hex wrench to loosen the set screw and remove the entire handwheel/collar unit.)

The designations of the axes of movement are different in lathe and mill configurations. A lathe used with a vertical milling column is considered a mill when it comes to naming the axes.

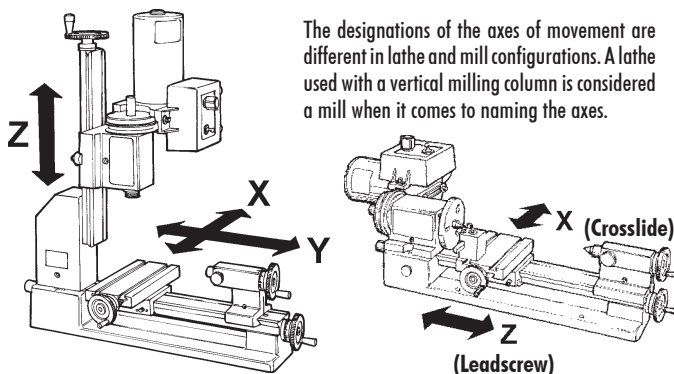

FIGURE 1A—Installing the new thrust collar on the crossslide screw.

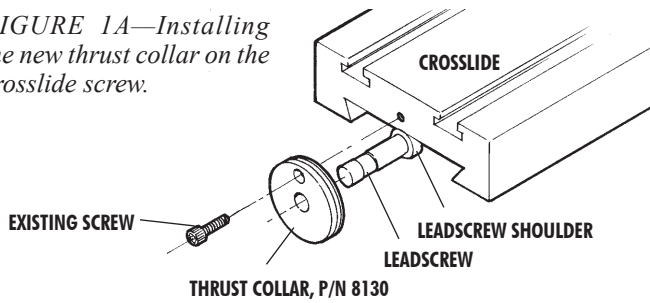
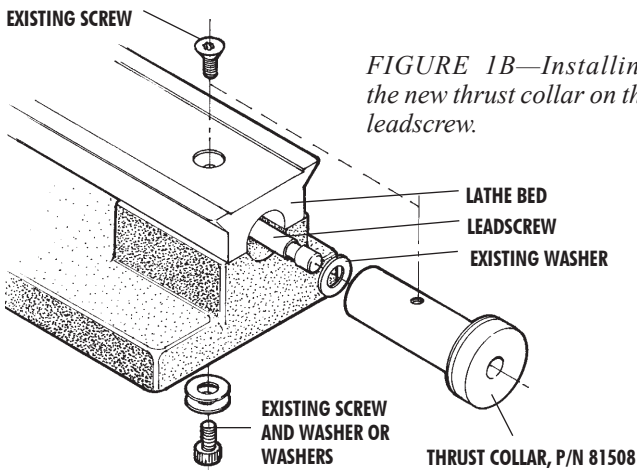

FIGURE 1B—Installing the new thrust collar on the leadscrew.



4. Using a 3/32" hex wrench, remove the 5-40 screw holding the thrust collar over the crossslide and remove the collar. (See Figure 1A.) Use a 1/8" hex wrench to remove the countersunk screw in the top of the lathe bed and a 5/32" hex wrench to remove the socket head cap screw under the lathe base so that the collar can be removed from the leadscrew. (See Figure 1B.)
5. Clean each grooved thrust collar with a solvent like acetone or lacquer thinner to remove any oil from the surface. (You will later lock them in place in relation to the plastic housing with "instant glue" and it will not stick to an oily collar.) Using the existing screws, install new grooved thrust collars on the X- and Y-axes, making sure the leadscrew is centered in the collar. Make sure the screws are secure, but do not overtighten. If a shim washer was present on your existing leadscrew, reinstall it as it was before.
6. Install a new handwheel with encoder ring on the crossslide screw and leadscrew. Note that the handwheels are similar except on the leadscrew, the numbers face away from the handwheel. On the crossslide they face toward the handwheel. Make sure the shoulder at the end of the leadscrew thread is seated against the thrust collar and the handwheel is pushed in tightly to remove end play before tightening the set screw. On the crossslide, push the crossslide table toward the bed so that the collar is securely against the shoulder



FIGURE 2—Making sure the crossslide screw is centered

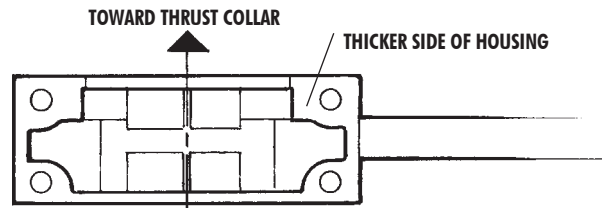

FIGURE 3—Detail of the encoder housing showing direction of installation

of the leadscrew. On the leadscrew, hold the table (not the base) with one hand and push the handwheel onto the shaft with the other. Rotate the handwheel so that the set screw tightens on a new part of the shaft. If you don't, it will tend to pick up its old indentation making it difficult to tighten it in a new position.

See Figure 3 for orientation of the encoder housing. The thicker shoulder inside the encoder should be facing toward the thrust collar. It is easier to tighten the screws if you install the units upside down with the screws coming down from the top. Place the two halves of the shell over the thrust collar and over the encoder ring and install the four #2 x 3/8" self-tapping screws. Draw the screws down

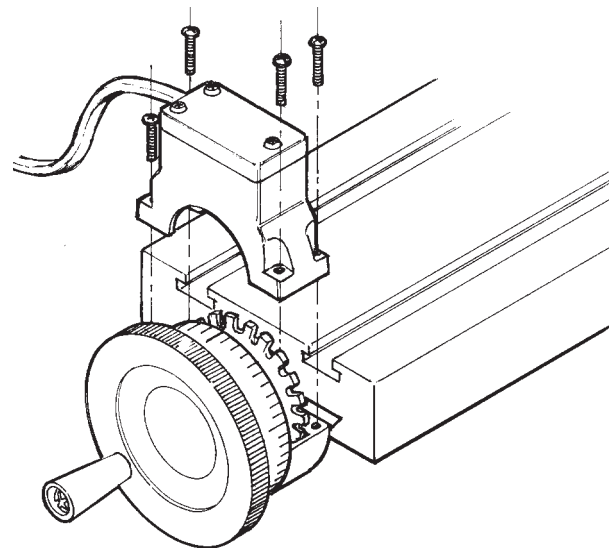

FIGURE 4—Installing the encoder unit over the thrust collar. The unit can be installed upside down to make it easier to put in the screws. It is then rotated into position and tightened to lock it in place.

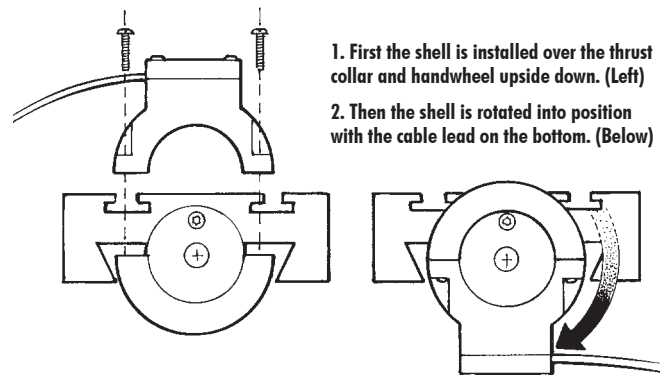
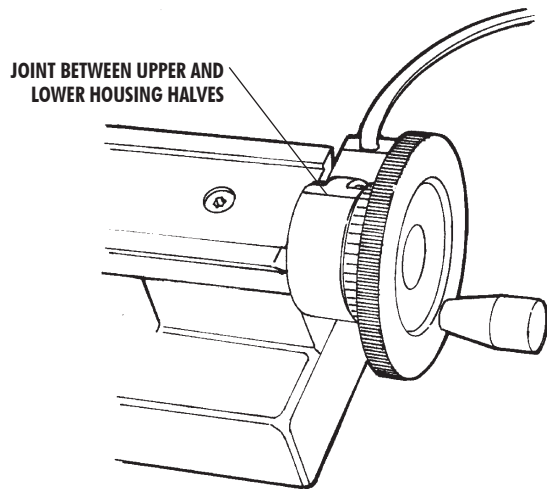

FIGURE 5—Rotating the unit into its proper position. (Note: Handwheel/encoder unit not shown for clarity.)

until they seat snugly, but **DO NOT OVERTIGHTEN** or you will strip the threads! Once tightened into position, the unit can be rotated around until the screws and cable are on the bottom. When finished, the cable from the encoders should come off to the right side of the handwheel.

FIGURE 6—On the long bed lathe, the leadscrew handwheel sensor housing must be positioned as shown.



Leadscrew Handwheel Position on the Model 4400 Lathe

The die cast base on the Model 4400/4410 long bed lathe is relieved so that the bed and base align. The lip on the bottom of the machined area will keep the sensor housing from being able to be rotated straight down. The solution to this is to orient the housing as shown in Figure 6 above. The joint between the two halves of the housing now becomes the witness mark against which you read the handwheel markings. On the Model 4400/4410 lathe, the bed and base are flush at the end, so the housing can be positioned straight down as is shown in the other figures.

Making Sure the Housings do not Move

The sensors that read gear-tooth position as you turn the handwheel are located in the bottom of the handwheel housing. If the housing moves, it is the same as if you moved the handwheel, because it changes the relationship between the sensor and the gear tooth. Therefore, the housing should be anchored in place so that it cannot be inadvertently moved. The screws that hold the two halves together go into plastic, and overtightening them can strip the threads out of the hole. If the housing rotates too easily when the screws are tightened, you can remove the housing shell and sand the mating surfaces on a piece of sandpaper on a flat surface until they grip the collar more tightly. If this doesn't do the job, another solution is to place a drop of "super glue" between the plastic housing and the metal collar once the housing is positioned where you want it. This will keep it in place but can still be broken loose if you need to later.

7. **VERTICAL MILLING COLUMN**—Using a 1/8" hex wrench, remove the flat head screw that holds the Z-axis thrust collar to the vertical milling column. Remove the collar by lifting it up and off the leadscrew.

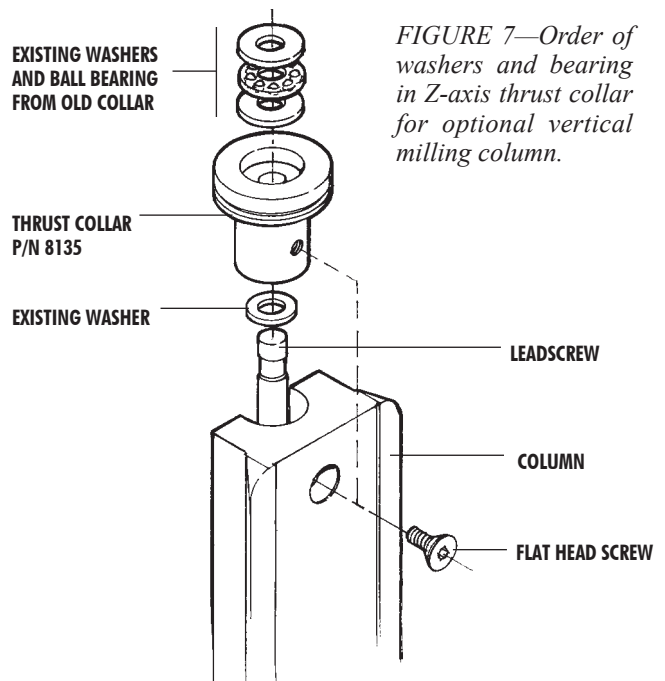

FIGURE 7—Order of washers and bearing in Z-axis thrust collar for optional vertical milling column.

If the spacer washer sticks to the bottom of it, remove it and reinstall it on the leadscrew shaft. Then remove the ball bearing thrust and two washers from the collar and reinstall them in the new Z-axis thrust collar in the same order. (See Figure 7.) Install the new collar on the leadscrew shaft and secure it to the bed with the flat head screw.

8. Install the remaining handwheel and encoder unit onto the vertical milling column leadscrew. Lift up on the saddle assembly until the washer and shoulder of the leadscrew are all the way up against the bottom of the collar. Then push down on the handwheel and tighten its set screw, being sure to tighten it against a new spot on the shaft. Install the pickup housing over the handwheel unit as shown in Figures 4 and 5. When finished, the cable should exit toward the left when viewed from the front.

Installing the RPM Sensor

1. Reinstall the headstock/motor/speed control onto the lathe or milling column.
2. Peel off the backing and apply the 2-1/2" round sticker to the pulley. (HINT: A little liquid window cleaner on the pulley allows the sticker to be repositioned and bubbles squeezed out before it adheres. Once the liquid is squeezed out and dries, the adhesive on the sticker will stick fine.)
3. Locate the RPM sensor by holding it in the position shown in Figure 7. Mark the center of the hole on the plastic belt housing and drill a 1/16" hole. Fasten the sensor to the belt housing using the self-tapping screw provided. (Do not overtighten or you can strip the threads.) A plastic tie-wrap is provided to secure the sensor lead to the motor's power cord to keep it out of the way.

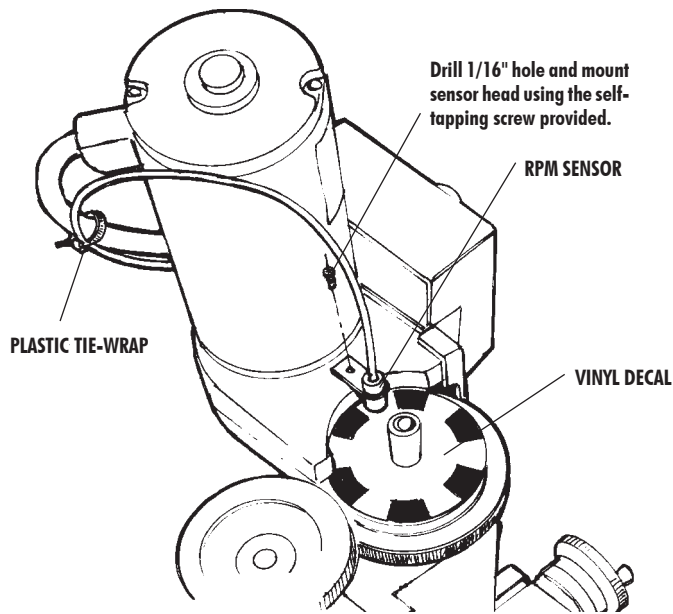

FIGURE 8—Mounting the sensor to the belt housing in the mill configuration. The mounting position would be the same in the lathe configuration.

NOTE: If you have a lathe with an older AC/DC motor that does not have a plastic belt guard, the RPM sensor can be mounted in the proper position over the pulley by attaching it to the motor mounting bracket. Locate and mark where the hole should be drilled. Remove the motor and drill a hole through the bracket. You can use a self-tapping sheet metal screw or a bolt and nut through the hole, or you can tap the hole to match the thread of the bolt you use.

Hooking Up the Connecting Cables

Plug the cable connector from each encoder unit into its respective port on the display unit. The telephone type cable connectors go in with the locking tab facing up when the unit is lying on its back. The RPM sensor cable goes into the port marked “Tach In”.

Plug the power adapter into the bottom hole marked “DC In”, and plug the transformer into a 115 VAC (60 Hz.) source. Check to make sure all three axes are functioning. Turn on the motor and check to see that the RPM indicator is functioning.

Initializing Your Display for Inch or Metric Leadscrews

When you press the “Power” button to turn your system on, the upper right corner of the display will read either “inch” or “metric” mode. Normally, the DRO will be set up properly when you receive it, but there is always a possibility it could be set wrong. To set or change the system of measurement your unit displays, follow these steps:

1. With the power off, unplug the power cable from the display unit.
2. **INCH**—Hold down both the “Power” button and the X-axis button while you plug the power cord back into the display unit. After the display comes up, release the buttons. The display should now read in inch dimensions.

3. **METRIC**—To initialize your display unit to read metric dimensions, hold down the “Power” and “Y” buttons while plugging the power cord back into the display unit. Once initialized, the unit will always read in your chosen system of measurement each time it is turned on unless you change it.

NOTICE! THE DISPLAY DOES NOT CONVERT DIMENSIONS FROM INCH TO METRIC!

The DRO reads rotary handwheel movement and converts it to a linear dimension based on a formula assuming a certain leadscrew thread pitch. The DRO must be set to agree with the leadscrews installed on your machine to provide accurate measurements.

The only difference between the inch and metric packages is the number of divisions engraved into the handwheels. The electronics package is the same for either and can be set to read in either measurement system depending on the leadscrews of the machine on which it is installed.

Setting the Backlash Compensation Values

To set backlash compensation for each axis, you must first measure to determine what the backlash is. Use a dial indicator to determine how far the handwheel on each axis rotates before the table starts to move. (If this amount is excessive, see your instruction manual for instructions on setting backlash. It should ideally be in the .003" to .005" range.) Once the amount is determined, the backlash is compensated for by setting it into the display unit's memory.

To set the backlash to correspond to your machine's leadscrews, complete the following steps for each axis:

1. Turn the handwheel for each axis one full turn clockwise. This assures that the software starts the backlash compensation at the proper initial point.
2. Hold down the “Power” button for longer than a second until the display changes.
3. Now you can set in the backlash for each axis by pushing the button for that axis. Each time the button is depressed, .0005" (or .01 mm on metric units) is added to the reading. Set in the amount of backlash you measured previously for each axis. Amounts up to .015" (.50 mm) can be set. (Note: You cannot cycle backwards to a lower number. If you go past your desired setting you must continue pushing the button until the reading passes .015" (.50 mm) and returns to zero. Then start over.)
4. Once the backlash for all three axes is set, briefly push the “Power” button again to return the display to its normal reading. The backlash setting can be checked or changed at any time by holding the power button until the display changes. The amount can then be reset as described in instruction number 3 above. Once set, backlash settings are held in a special memory chip even if the unit is turned off and unplugged. They remain until you change them.

Using the DRO with the Sherline Power Feed or Thread Cutting Attachment

The DRO leadscrew thrust collar is longer than the standard thrust collar so that the DRO housing can attach to it. This changes the position of the leadscrew. This has no effect on the lathe except when it is used with a power feed or thread cutting attachment. In those cases you will need to replace the existing sliding engagement shaft (P/N 1509) which will be a little too short. If you return the existing shaft to Sherline it will be replaced at no charge with a shaft of the appropriate length (P/N 81509) for use with the DRO. If you purchase a new power feed or thread cutting attachment, notify Sherline that you will be using it with the lathe DRO and the proper shaft will be supplied with your purchase. The only alternative to solving this problem would have been to provide a longer leadscrew which would have been far more expensive.

Adjusting the Z-Axis Handwheel Screw

To adjust tension on the screw, first remove all Z-axis backlash in the conventional manner by lifting the motor/speed control unit by hand while tightening the handwheel set screw on a "fresh" quadrant of the leadscrew to avoid picking up any previous indentations. Once adjusted, tighten the new center screw only until it is "finger tight". Use a very small amount of Loctite® on the end of the screw to keep it in place. (Do not coat the threads or the screw may become impossible to remove.) Overtightening the screw will cause the handwheel to become hard to turn. The purpose of the screw is not to adjust backlash, but rather to keep it from increasing once it is properly adjusted. Do not try to use the screw to pull out additional backlash. The small 5-40 threads are not strong enough for this task.

A Few More Tips

When in use, shield the unit from chips so they don't accumulate around the telephone jack connections on the side. Do not use an air hose to clean the unit.

A metal stand is now included with your DRO so you can stand the unit up on your workbench. This makes it easier to read while you work. If you wish to secure the box to the stand, a piece of double-sided foam tape is a good method.

Getting the Most Out of Your DRO

When using a machine equipped with a digital readout, we find it is best to use either the readout or the handwheels, but not both. If the displayed accuracy of .0005" (.01mm) is satisfactory for the job you are doing, use just the digital readout and disregard the handwheel settings. In cases where you might want to interpolate to a higher degree of accuracy, the markings on the handwheels will allow you to do this.

An example of this would be where you have located the center of a bored hole and then changed the table position. To return the spindle exactly to the hole's center again using the digital readout could leave you a few ten-thousandths off, which may not be acceptable. In this case, you should write down your handwheel settings and direction the handwheel was last turned before moving from the desired location. This will allow you to return to the same spot with great accuracy. The handwheel marks are .001" or .01mm apart. By reading the space between the marks on the handwheel and interpolating your position, you can achieve a high degree of accuracy. Knowing your machine is an important part of achieving this kind of accuracy, and as you get more familiar with your machine, your accuracy will continue to improve.

Sherline's DRO brings modern machine shop technology down to tabletop size and makes your Sherline tools easier and more fun to use. We think you will find the digital readout to be a great addition to your Sherline machine shop.

Thank you,
Sherline Products Inc.

P/N 8200 Digital Readout

Exploded View and Parts Listing

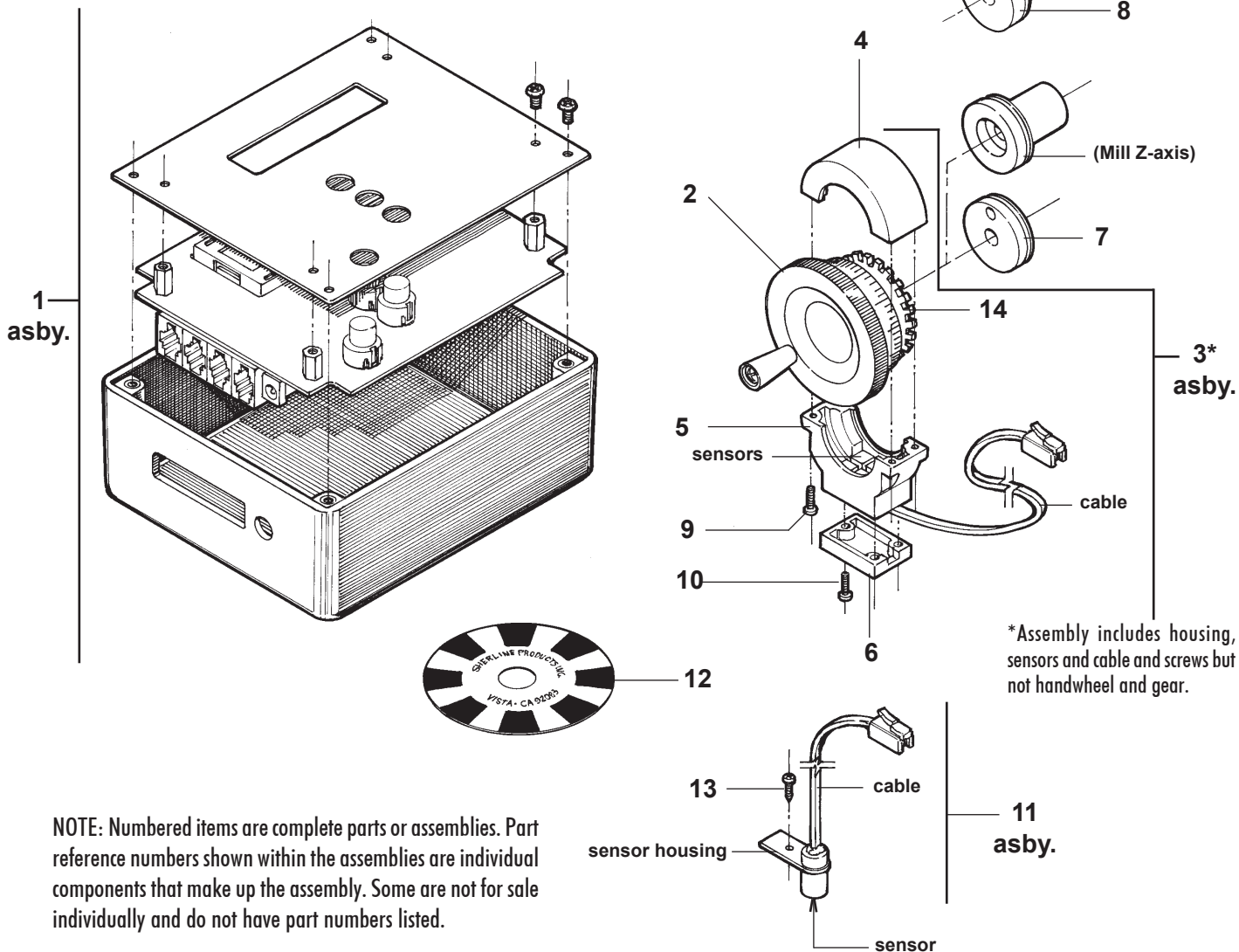

NOTE: Numbered items are complete parts or assemblies. Part reference numbers shown within the assemblies are individual components that make up the assembly. Some are not for sale individually and do not have part numbers listed.

REF. NO.	PART NO.	DESCRIPTION	REF. NO.	PART NO.	DESCRIPTION
1	81010	Mill DRO box and electronics (complete)	10	81270	2-56 x 3/8" pan head Phillips screw
2	81320	Crossslide handwheel, inch (Met. 81322)	11	81500	Tachometer encoder & cable asby.
	81330	Leadscrew handwheel, inch (Met. 81332)	12	81510	Tachometer pickup decal
3	81100	Encoder housing w/ wheel and cable	13	40440	#2 x 1/4" Self-tapping pan head screw
4	81110	Encoder housing upper cap	14	81310	Encoder star gear
5	81120	Encoder housing body	--	81080	Black tie-wrap (not shown)
6	81130	Encoder housing lower cap	--	81050	115 VAC Power supply/transformer (not shown)
7	81300	Crossslide thrust collar	--	81150	Stand for readout display box (not shown)
8	81508	Leadscrew thrust collar	--	41050	Z-axis support screw (not shown)
9	81280	#2 x 3/8" Self-tapping pan head screw			