

P/N 7600 tool post with P/N 2256 RH inserted carbide tip tool holder, 55° carbide tip and Torx wrench

SHERLINE
PRODUCTS
INCORPORATED 1974

Carbide Cutting Tool Inserts and Holders

Sherline has teamed up with Valenite™ to bring the home shop machinist cutting tools that add a new dimension to small lathes. High speed steel has short tool life and brazed carbide chip easily. Inserted carbide cutting tools have replaced these tools in the modern machine shop.

The proper carbide insert has the ability to consistently give good finishes and long tool life at a much higher cutting speed. This is especially important with small lathes because they don't have excessive power at low RPM. You can use inserted carbide tools to cut stainless steel at the same RPM you were formerly using to cut aluminum with high speed steel tools without any sacrifice of quality in surface finish.

Carbide tools are not inexpensive, but they are worth every penny if you have problems grinding your own high speed steel tools or cutting exotic materials such as stainless steel.

If you would like a good, solid, easy-to-use holder for these carbide tips, we suggest you start with the number 2256 right hand holder that uses the number 7605 insert tip. This 55° insert is good for turning, facing and profiling. The inserts are offset 35° to either the right, (2256) or left (2257) and can be purchased as a pair (2258) which yields a substantial cost savings.

The 55° inserts have the advantage of being able to cut a larger number of different shapes. The 80° inserts are slightly less versatile, but offer the advantage of longer tool life due to the stronger, more square shape.

Boring bars come in a standard 6-inch length and are intended to be cut to length for each specific use. The 80° boring bar is intended for boring straight holes, while the 55° tool can do certain types of inside diameter profiling. Remember there is a minimum hole diameter for I.D. boring bars. (See tables on the following page.)

Sherline does not recommend attempting to cut hardened steels or piano wire with these inserts. Materials such as these should be ground to shape, not cut. However, abrasive materials such as glass reinforced plastics can be easily cut with these tools.

The main purpose of using a diamond insert is to true up commutators used in electric motors. The most unique aspect of this tool is that the diamond has four cutting edges. Although the initial cost may seem high, when you consider you are really getting four cutting surfaces rather than one, the cost in relation to the usefulness of the tool is quite reasonable. Diamonds, while expensive, are capable of giving mirror-like finishes to copper or aluminum. Never attempt to cut steel with the diamond cutter. (NOTE: Cutter holder no longer available from Valenite as of 9/04)

PLEASE NOTE: The inserted carbide and diamond cutting tools offered by Sherline will improve the performance of the Sherline lathe, but they will not correct poor machining technique. Rigid setups are a must for tools such as these.

These tool posts are designed to hold the tools shown on this sheet. All Sherline tool posts are machined from solid aluminum and have a black anodized finish for long life.

Insert Holder Tool Posts

Fits all 3/8" round and square insert holders

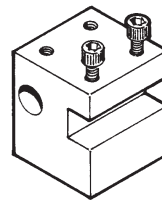

P/N 7600

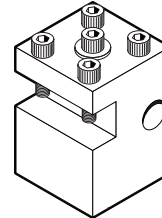

P/N 7604

These tool posts fit the larger 3/8" size tool holders used for carbide or diamond inserted tips. In addition to the slot for a 3/8" lathe cutting tool, a 3/8" diameter hole is provided for holding round boring tools. Tool post P/N 7600 will allow you to keep your standard P/N 40180 tool post available for use with 1/4" high speed steel tools for jobs where they are sufficient, or a specially ground and shaped tip is required.

The P/N 7604 holds 3/8" square tools on the "back" side of the part. The rear-mount tool holder allows the tool to be mounted upside down and used on the back side of the crossslide.

Insert Holder Riser Tool Posts

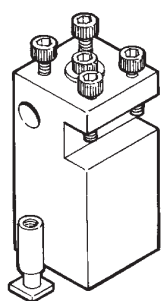

P/N 1289

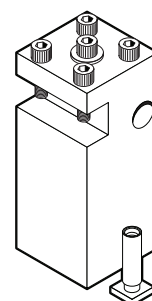

P/N 1287

Riser tool posts are taller than their shorter counterparts. The taller posts are to be used when you have riser blocks installed on your lathe headstock. P/N 1289 is for use on the front side of crossslide, while P/N 1287 is a rear-mounted post to be used on the back side of crossslide, similar to P/N 7604.

Two-Position Rocker Tool Post

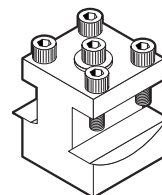

P/N 7603

This tool post has slots on two opposite sides to hold both 1/4" and 3/8" square shank tools individually or at the same time. This allows you to switch quickly between tools of the two different sizes simply by rotating the tool post 180°.

Thank you,
Sherline Products Inc.

Cutting Tool Inserts and Insert Holders

55° Insert Holders—Left-hand and Right-hand

PART NO.	DESCRIPTION	TOOL POST	INSERT
2256	55° RH Holder (w/ insert)	7600*	7605
2257	55° LH Holder (w/ insert)	7600	7605
2258	PAIR, RH & LH (w/ inserts)	7600	7605
7605 7605B	55° Carbide Insert (2 Cutting Edges)	Each Box of 10	

55° Holders

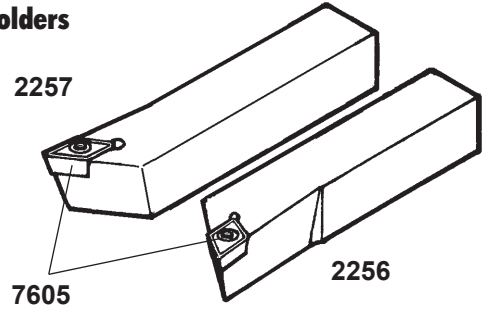

*NOTE: Tool post not included. Part numbers are provided for your convenience so you can see what is needed for a complete set. The P/N 7600 tool post is \$20.00 and the insert prices are listed at the bottom of each section. P/N 2256, 2257 and 2258 come with one insert per holder as part of the price. All other insert holders do not come with an insert.

One carbide insert plus a hold-down screw and hex key are included with each holder. These holders will also accept the 7611 55° diamond inserts shown below.

3/8" Diameter Boring Bars—80° and 55°

PART NO.	DESCRIPTION	TOOL POST	INSERT
2259	80° Boring Bar w/ insert*	7600	7608
2260	55° Boring Bar w/ insert**	7600	7605
2261	Set of both of above holders	7600	7608, 7605
	* Minimum Hole Diameter: .50" ** Minimum Hole Diameter: .75" Max hole depth approx. 2" (Total tool length 3.25")		

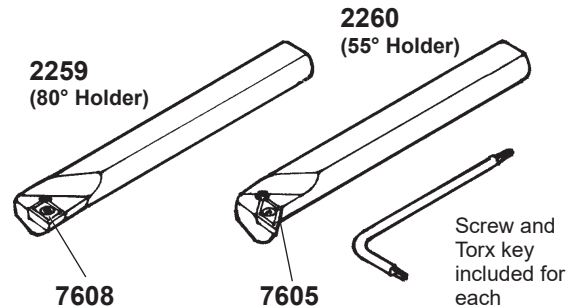

Outside Threading and Grooving Insert Holders

PART NO.	DESCRIPTION	TOOL POST	INSERT
2267	Threading & Grooving Insert Holder Only	7600	7606, 7660
2268	60° Threading Insert (2 Cutting Edges)	Each	7605
2269	.031" Grooving Insert (2 Cutting Edges)	Each	7605
2270	.062" Grooving Insert (2 Cutting Edges)	Each	

Outside Threading & Grooving Tool

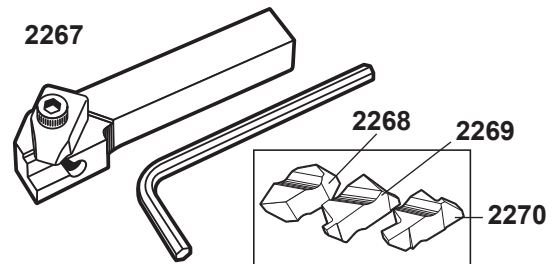

Diamond Inserts

PART NO.	DESCRIPTION
7609	Diamond Insert (4 Cutting edges, Fits Valenite holder.)
7611	55° Diamond Insert (1 Cutting edge, Fits Sherline LH, RH and Boring 55° carbide tool holders)

Diamond Cutter

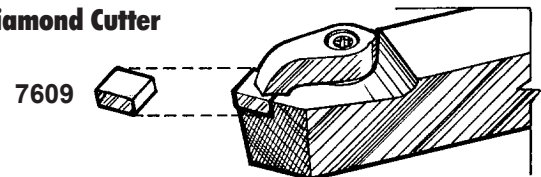

(Valenite holder no longer available)

NOTE: Valenite no longer offers this holder. For those who already own this holder we still offer replacement diamond inserts for it. The alternative for new purchasers wishing to use diamond inserts is the 55° holder 7611 above that fits our standard Sherline 55° holders.

WARNING

Carbide cutting tips may chip or fragment in use. Always use machine guards, protective clothing and safety glasses to prevent burns or other injury to body or eyes from flying particles or chips. Grinding produces hazardous dust: To avoid adverse health effects, use adequate ventilation and read Material Safety Data Sheet for applicable carbide grade first.

For Data Sheet write to:

VALENITE, 31100 Stephenson Hwy., Madison Heights, MI 48071

Specifications subject to change without notice.