



Clockmaker's Arbors and Pot Chucks

Arbors P/N 2090 through 2093

Gear-cutting Arbors P/N 2094 through 2096

10mm "D" Pot Collets P/N 2103 through 2105

These arbors are not designed to be used on Sherline lathes, but rather are specifically suited to the types of lathes often used by jewelers and watch makers. Though highly accurate, these machines are often not very versatile.

The 3/4-16 arbors provide a way to mount a Sherline 3-jaw or 4-jaw chuck to this type of lathe. The 3/8-24 arbors

allow a 1/4" or 3/8" drill chuck to be mounted. The ability to mount these chucks adds a great deal of versatility to this type of special purpose tool.

With use of a 8 mm adapter (P/N 11560) either of the 8 mm arbors can also be used on Sherline lathes, although the normal system for mounting chucks is recommended.

Clockmaker's Arbors

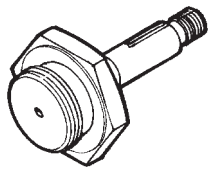

P/N 2090
Clockmaker's arbor
8 mm to 3/4"-16

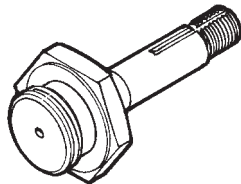

P/N 2091
Clockmaker's arbor
10 mm "D" to 3/4"-16

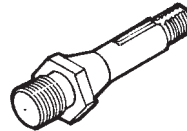

P/N 2092
Clockmaker's arbor
8 mm to 3/8"-24

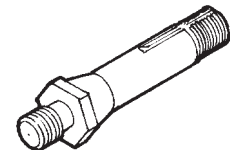

P/N 2093
Clockmaker's arbor
10 mm "D" to 3/8"-24

Clockmaker's Gear-cutting Arbors

The P/N 2094 gear-cutting arbor with its #1 Morse taper can be used directly on your Sherline lathe or mill. These gear-cutting arbors have a removable bushing that allows

them to accommodate gear-tooth cutters with two different center hole sizes. P/N 2096 can be used on a Sherline lathe or mill with the 8 mm collet adapter P/N 11560.

P/N 2094
Clockmaker's gear-cutting arbor
7 mm to Morse #1 taper

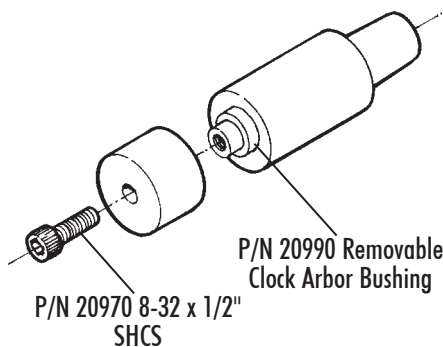

P/N 2095
Clockmaker's gear-cutting arbor
7 mm to 10 mm "D" Collet

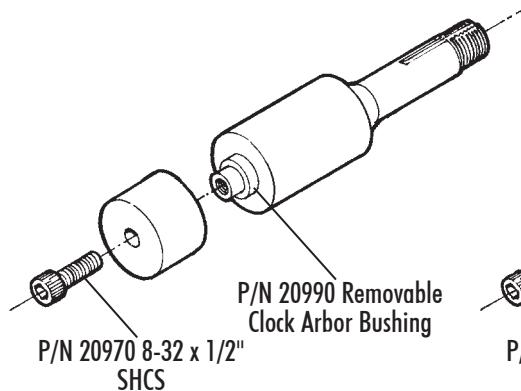

P/N 2096
Clockmaker's gear-cutting arbor
7 mm to 8 mm WW Collet

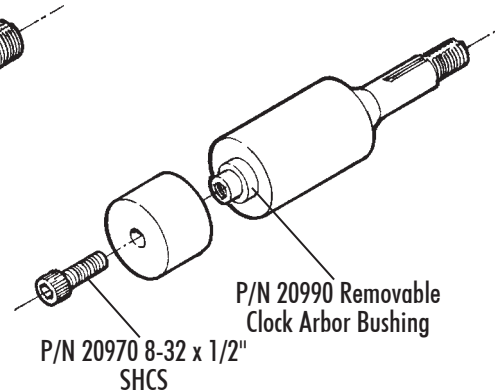

8 mm (WW) and 10 mm "D" Collet Pot Chucks

These collets fit a 10 mm spindle and are designed to hold larger and odd shaped pieces. The collets are split and have a 1/8" hole through. They are to be bored to fit your application. This is accomplished by tightening the collet in a lathe on the 1/8" pin supplied and boring the collet to the size needed. The depth of the bore shouldn't exceed .200" (5 mm). The diameter shouldn't exceed .625" (16 mm) on the 3/4" pot collet, .875" (22 mm) on the 1" pot collet or 1.125" (29 mm) on the 1-1/4" pot collet.

NOTE: Pot collets are designed to hold material only on the face end, not through the collet.

Part numbers for the collet pot chucks are as follows:

8 mm: (WW)

3/4"—P/N 2100

1"—P/N 2101

1-1/4"—P/N 2102

10 mm "D":

3/4"—P/N 2103

1"—2104

1-1/4"—2105

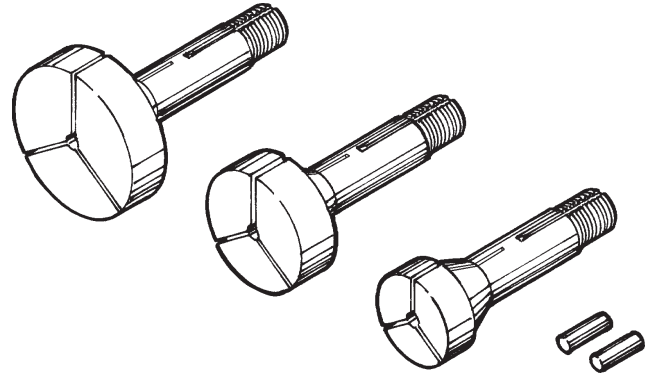

"Pot" or "step" collets and dowel pins. Sizes are 1-1/4", 1", and 3/4". They are shown with the 10 mm "D" shaft, but are also available with an 8 mm shaft, which fits watchmaker's lathes sized for WW collets.

Collet sizes: Sherline WW collets vs. 8 mm collets

We are often asked what are the dimensions of our WW collets and are they the same as 8 mm collets. Sherline WW collets have a body diameter of .312" to .313" and a .275-40 external thread. 8 mm collets generally have a body diameter of .314"-.315". Sherline collets will fit in an 8 mm holder, but if you have 8 mm collets you need to hold in a Sherline lathe, we do offer a collet adapter with a slightly larger hole for that size as well as Sherline's WW size. The 8 mm adapter and drawbar set is P/N 1163.