

## Tailstock Spindle Extender

P/N 1220

A miniature lathe by its nature and design must fit the most function into the smallest space. This means that to turn an 8" long part on a lathe only 15" long, the tailstock cannot have too much overhang over the table. For Sherline lathes manufactured before 7/96, the tailstock spindle extender provides this overhang while retaining the stability of the tailstock spindle by not requiring that it be cranked out to its maximum extension to reach out over the table. (A modification to the design of the tailstock eliminates the need for this part on machines manufactured after 7/96. See Fig. 2.)

Certain setups are made much easier by using the tailstock spindle extender because it adds 1-1/2" to the reach of the tailstock spindle.

By using the extender, a part being held between centers can be turned from end to end on machines with the older style tailstock without having to move the toolpost from one position to another to keep the crossslide saddle from hitting the tailstock. Figure 1 below illustrates how a piece of tubing held in a 3-jaw chuck and a live center can be turned from end to end with one tool post position.

You will no doubt find other occasions as well where this simple tool pays for itself many times over in convenience.

Thank you,  
Sherline Products Inc.

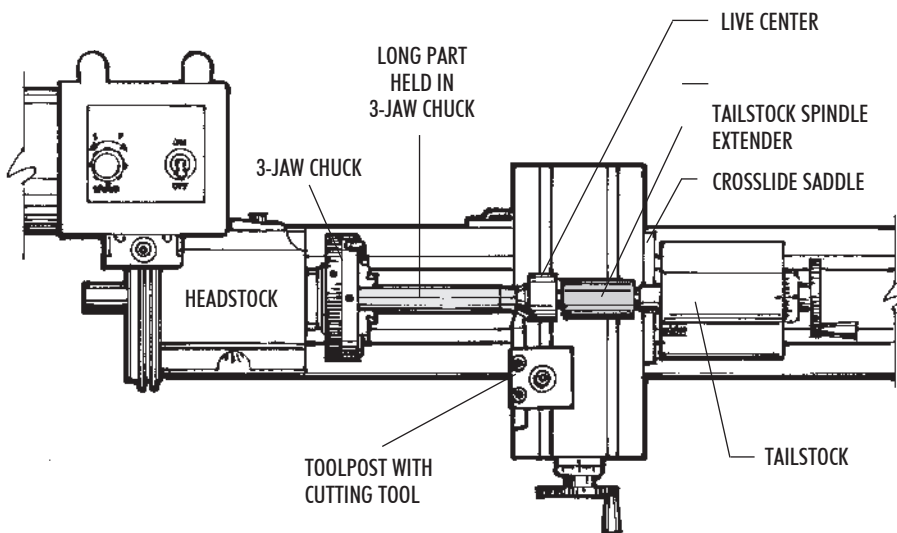

FIGURE 1—Top view of lathe with a part held between centers. The spindle extender moves the live center out an extra 1.5" so the saddle won't hit the tailstock when machining from one end of the part to the other in a single setup.

FIGURE 2—A) Tailstock made before 7/96 with P/N 1220 tailstock spindle extender clears bed without extension of spindle.

B) Newer design requires minimal spindle extension but will clear table without use of the spindle extender.

