



SHERLINE STEPPER MOTOR SPECIFICATIONS—NMB MOTORS

Sherline P/N:	67127 (w/ DIN plug and flats on shaft) 67130 (no plug, flats on shaft)
Manufacturer:	NMB (Minebea Co. Ltd.)
Mfg. P/N (Type):	23KM-K035-62V (double shaft)
Frame size:	NEMA #23
Step angle:	1.8°
Voltage:	3.2 V DC
Current:	2.0 A/Φ
Resistance:	1.6 Ω/Φ
Inductance:	3.6 mH/Φ
Holding torque:	.775 N.m (Newton meters) 7.9 kg-cm 109.71 oz/in (ounce inch) 6.856 in/lb (inch pound)
Rotor inertia:	250 g-cm ²
Number of wire leads:	6 (See color code diagram FIG. 2)
Weight:	1.32 lb (0.6 Kg.)
Length:	2.13" (54 mm)
Shaft:	Double ended, 1/4" diameter

See figure 3 for the pin diagram and wire color layout of the stepper motor connector cables we supply with our stepper motors. Since there is no industry standard for wire colors in this field, if using a connector not supplied by Sherline each pin and color should be confirmed with a continuity tester before applying power.

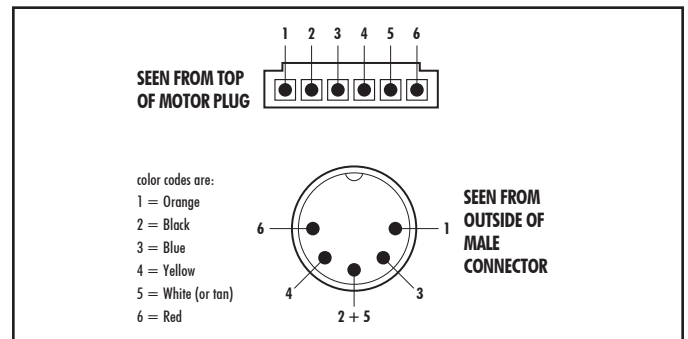

FIGURE 3—This diagram shows which pin in the DIN connector is wired to which position in the motor connector.

NOTE: Motors can be wired in either unipolar or bipolar configuration depending on how the leads are connected. Sherline motors with plugs are wired for unipolar operation.

PRECAUTIONS

- Make sure the ends of raw wires are not touching each other when turning the handwheel by hand to drive the stepper motor and leadscrew. It can cause the motor to feel rough and hard to turn.
- DC motors generate current when hand cranked that can damage the control unit. When positioning a stepper motor by hand using the handwheel, do not crank faster than about 1 rev/second. For long travels, use the jog mode of your CNC control software.
- Poor connections can cause arcing, which can burn out motors or control chips. Always make sure plugs and connections are fully engaged and making good contact.
- Always turn off driver box power before plugging in or unplugging a stepper motor.

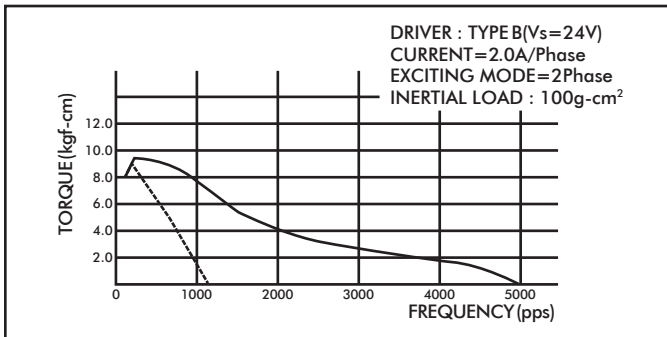

FIGURE 1—Motor torque curve

Lead Wire Connection and Color Code

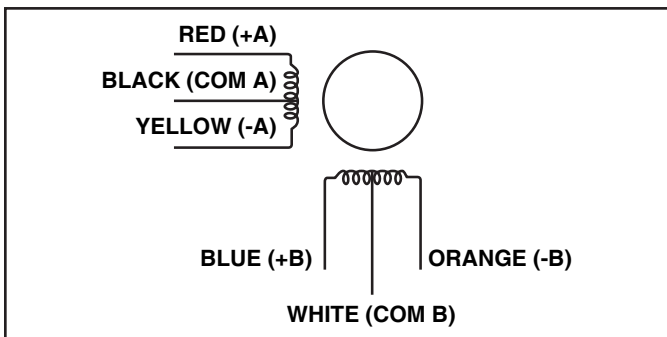

FIGURE 2—Color of internal wiring for NMB motors