

Index Block Set

P/N 2045

If you have ever been around a tool room in a standard machine shop, you have probably come across index blocks for 5C collets. They can save a great deal of time when doing simple indexing. It seemed like a good idea to add them to our line, so we included a couple of features for Sherline users. Rather than design them in a “six and four” configuration, we chose “eight and six”, which adds more choices without adding cost.

We designed the blocks to use all of our spindle accessories rather than a particular collet size. If a tool fits the spindle of your lathe or mill, it will fit the indexer. Standard drawbolts can be shortened or new ones can be purchased at any hardware store. The way we manufactured the index blocks kept the flats accurately machined in relation to the centerline of the spindle mount, so they should yield quite accurate results.

When put in use, the index block is held in a vise. To index your part, all you have to do after performing your operation is loosen the vise, index the part to the next surface and retighten the vise. For example, a part could be turned on the lathe in a 3-jaw chuck. The chuck could then be removed and screwed onto the threads on the end of the indexer. Then a hole pattern of 2, 3, 4, 6, or 8 holes could be drilled and tapped in the part using the indexer. In this case, the vise would be mounted on the side (See Figure 2). Likewise, flats could be machined to produce a special hex bolt with the vise clamped flat to the table.

To use tools or holders in the Morse #1 taper, you will need to use drawbolts that are shorter than the ones normally used in the headstock spindle. For mill collets that use a 5/16-24 drawbolt, a 1-5/8" length bolt will be needed. For 1/4-20 drawbolts used with the Morse #1 blank or drill chuck, a 2-1/4" length is needed. If you have extra drawbolts, they can be cut to length or new bolts can be purchased from any hardware store. Use the drawbolt washers that come with the drawbolts. If you need to purchase the washers separately from Sherline, the part numbers are P/N 30842 (5/16" drawbolt washer) and P/N 30882 (1/4" drawbolt washer) (See Figure 1). A special drawbolt is available (P/N 11681) to hold WW collets in the #1 Morse taper in conjunction with a WW collet adapter (P/N 11580).

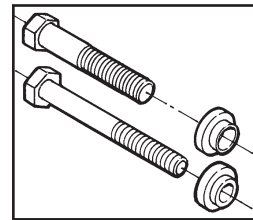

FIGURE 1—(Left) Drawbolt washers are used with shortened drawbolts.

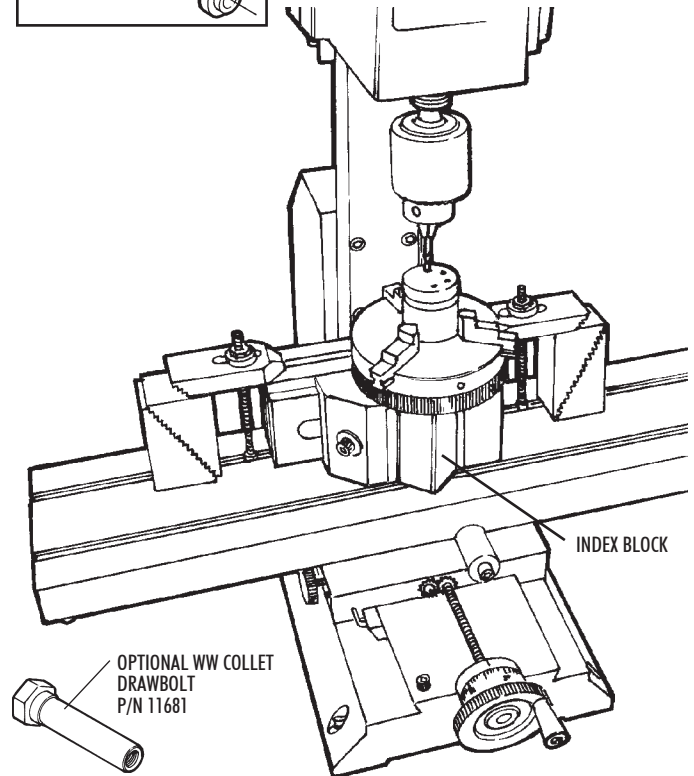

FIGURE 2—A part turned in a chuck on the lathe is transferred to an index block and held in a mill vise while a 6-hole pattern is drilled. The vise could also be clamped flat to the table for milling flats or drilling holes on the side of the part. The vise is shown being held in position on its side with blocks from two P/N 3013 step block sets.

This indexing set is one of those accessories that you will keep finding more uses for the longer you have it around. It is easy to use and a real time saver.

Thank you,
Sherline Products Inc.