

(NOTE: Replaced by P/N 1270 as of 4/98)

Compound Slide

P/N 1080

Instructions for Use

A compound slide is used to cut angles or tapers that cannot be cut by "swinging the headstock" (See page 12 in the printed instruction manual that comes with your machine or refer to the section on taper turning in these on-line instructions.) The slide has 1-1/2" of movement and is designed to be mounted either on the front or rear of the crossslide.

To mount the slide to the lathe crossslide, the T-Nut is loosely attached to the socket head screw which protrudes through the bottom of the fixed spindle slide. Slide the T-nut into the slot desired on the crossslide and locate and align the compound slide as required by your set-up. In order to tighten this screw, the compound lead screw must be turned all the way forward until the screw head aligns with the 5/16" hole on top of the compound slide (located in the center of the four tool hold-down screws).

One of the problems with designing and manufacturing metal cutting equipment of this size is that the operator can physically be stronger than the machine, which is not normally the case when operating machinery. An example would be a 10 pound force applied a couple of inches out on a hex key becomes a 650 pound (approx.) force at the tip of the screw. If you tighten both screws that tight on this tool post, it becomes 1300 pounds (approx.) of force on relatively small parts. The point we're trying to make is that over tightening can deform the Compound Slide to the point that it will bind and drag. It is not necessary to over tighten this device if you take light cuts.

The compound slide has been designed to be either mounted on the front or rear of the crossslide. When used on the rear slide, the tool bit must be mounted upside down with a 1/4" square tool bit used for a shim under it in order to return the tool to the proper height for cutting in this position. (A 1/4" tool bit is included for this purpose.) The reason the compound slide has been designed in this manner is to eliminate interference with the handwheel on the crossslide.

When used on the front, the slide tool can be held down directly without the shim. NOTE: Many angles may be cut from the front if you desire to do so. The crossslide is in square with the centerline of the headstock spindle.

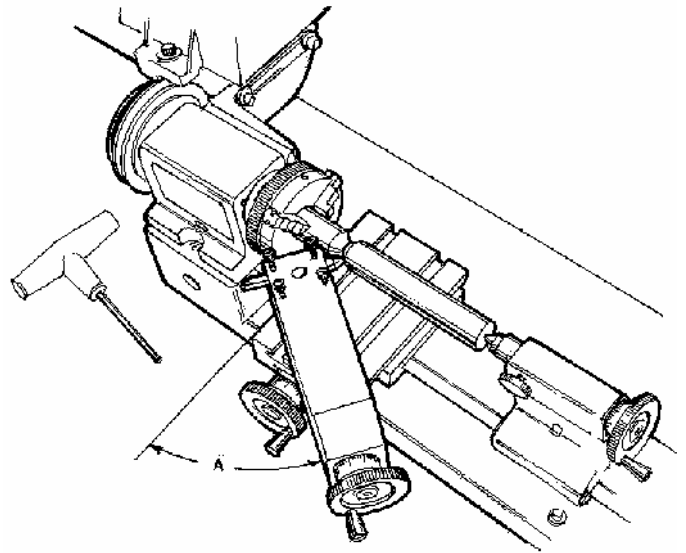

FIGURE 1—Compound slide mounted to crossslide and being used to cut a tapered groove in a part turned between centers. Angle of cut can be measured at "A".

Therefore, you can use a protractor and line up the edge of the compound slide aligning it from the edge of the crossslide to achieve the desired angle for your cut.

PLEASE NOTE... This compound slide was not designed for taking heavy cuts.

Thank you,
Sherline Products Inc.

Parts List

NO. REQ.	PART NO.	DESCRIPTION
1	1081	Compound Body
1	1082	Fixed Spindle Slide
1	1083	Compound Lead Screw
1	1084	Compound Tee Nut
1	1085	10-32 x 1/4" Skt Hd Cap Screw
1	1086	Compound Slide Plug
1	4005	Handwheel
4	4069	10-32 x 3/4" Skt Hd Cap Screws