



PRODUCT DESCRIPTION

- 6550—8" Manual slide, inch (6551, metric)
- 6552—8" CNC-ready slide, inch (no motor) (6553, metric)
- 6554—8" CNC slide w/stepper motor and controller (6554M)
- 6555—13" Manual slide, inch (6556, metric)
- 6557—13" CNC-ready slide, inch (no motor) (6558, metric)
- 6559—13" CNC slide w/stepper motor and controller (6558M)
- 6550-18—18" Manual slide, inch (6551-18, metric)
- 6552-18—18" CNC-ready slide, inch (no motor) (6553-18, metric)
- 6554-18—18" CNC slide w/stepper motor and controller (6554M-18)

8", 13", or 18" Single-Axis Industrial Machine Slide

P/N 6550 through 6559

Configurations

The single-axis machine slide is available in either manual or CNC-ready configuration. The table length can be either 8", 13", or 18", and any table is available with either an inch or metric leadscrew. In addition, the table can be ordered with a stepper motor installed and a self-contained, programmable controller to drive the stepper motor.

Mounting the Machine Slide

FROM THE BOTTOM—Four 1/4-20 holes are provided in the bottom of the base on 2-inch centers for mounting. A drawing accompanies this sheet showing this and other details of the slide.

FROM THE TOP—If access is not available from the bottom, the slide can be mounted from the top using the four angle clamps provided. They slide into the groove around the perimeter of the base, and holes are drilled in the mounting surface and tapped to accept the 10-32 socket head cap screws provided. Use all four clamps for the most secure mount.

Use of the Single-Axis Manual or CNC Machine Slide

To lock the slide in position, tighten the screw in the clamp block (P/N 65502) on the side of the base. Handwheel graduations on the manual version are .001" or .01mm on metric models. Each full rotation advances the table .050" (1.0mm on metric models). In addition to the handwheel, CNC versions have a coupler and mount to accept a stepper motor with a 23 frame size. When mounting accessories to the table using the T-nuts provided, make sure to use the proper length 10-32 screws or damage to the table can occur.

Weight Capacity and Duty Cycle

The weight capacity of our slides is about 10 lbs. depending on where the weight is located and how long the table is. On an 18" table you should not go more than 10 lbs. of weight at the end of the table (there is a leverage factor). If the weight is going to be more centrally located (closer to the base), then you can exceed the 10 lbs. limit.

Duty Cycle: Our tables are black anodized and the base is hard black anodized. We use our slides in our shop to manufacture our own parts. They run (8) hours a day, (5) days a week. Under this heavy constant use the dovetail area of the slide will start to show some wear on the anodize after one year (2080 hours). They are still fully functional at this point, but the anodize is beginning to wear thin. If you keep the dovetail and the screw lubricated with light oil, they will last longer.

The leadscrews have a rolled thread which is hardened a bit by the rolling process. The backlash nuts are brass. The nut is the softer material and therefore it is the part that wears out. The backlash nut is adjustable so it can compensate for the wear until the threads are gone. You should get the same (2080 hour) duty cycle from the backlash nut before it will need to be adjusted or replaced.

Lubrication and Maintenance

The leadscrew should be lubricated with light oil. Clean it periodically to make sure it is free from chips and debris. Lubricate the dovetail slide surfaces with a light grease. We have found a synthetic, Teflon®-based grease provides superior lubrication. The preloaded bearings are sealed and require no lubrication. The amount of preload on the thrust bearings is adjusted with the nut on the end of the leadscrew behind the handwheel collar (P/N 67106/67108). This nut draws the inner races of the flanged bearing together, eliminating end play from the handwheel or CNC coupler. After adjustment, the nut is locked with Loctite®.

NOTE: Do not use WD40 as a lubricant on these slides. WD40 will remove the anodized coating from these parts!

Backlash Adjustment

Leadscrew backlash is adjusted where the leadscrew enters the base. To adjust, loosen the button head screw (P/N 50120) that secures the star wheel lock. Tighten the toothed collar (P/N 50120) on the leadscrew to pull the leadscrew threads against the brass nut (P/N 40890/42890) inside the saddle.

When adjusted, re-engage the star wheel lock and retighten the button head screw to hold the collar in place. Backlash should be set to about .003". Attempting to eliminate it entirely will make the leadscrew too difficult to turn and cause premature wear. As on any machine, backlash is accounted for by always approaching your final setting from the same direction. (For more detail on backlash adjustment, see [Adjusting Leadscrew and Handwheel Backlash](#) on Sherline.com.)

Gib Adjustment

Gibs (tapered synthetic adjustment shims) are fitted to the mill headstock, saddle and table and to the lathe saddle and crossslide. Correct adjustment of the gibs will ensure smooth and steady operation of the slides. The gib is effectively a taper with an angle corresponding to the one machined into the saddle. It is held in place by an "L" wire gib lock which is secured with a locking screw.

An adjustable tapered gib is used to control "slop" between the table and the base. It is located underneath the table on the dovetail. To adjust, loosen the cup point set screw that secures the gib lock (P/N 40820) from the bottom of the base. Push the gib into the dovetail until the desired adjustment is achieved and then retighten the set screw to hold the gib in place. (Instructions for replacing worn gibs can be found at [Gib Replacement](#) on Sherline.com.)

Mounting Stepper Motors

It is important that the stepper motor shaft has a flat machined on it for the set screw. This is a must if you plan to remove the motor in the future. The flat should be located with its center .515" from the motor flange (not the boss).

To mount the motor, start by turning the leadscrew until the coupling set screw lines up with the access hole in the motor mount. Insert the motor shaft into the coupling. With the flanges touching, carefully rotate the stepper motor shaft until the flat on the shaft is aligned with the coupling set screw. Tighten the set screw. Rotate the motor to align the four mounting screw holes, and attach the motor to the motor mount.

Don't use Loctite® on the motor shaft set screw. The shaft could end up glued to the coupler.

Many Accessories Available

Sherline Industrial products are designed to accept Sherline's entire line of miniature machine tool accessories. Four 10-32 T-nuts and socket head cap screws are provided with this slide for mounting parts or accessories to the T-slots in the table. For example, some useful accessories include a mill vise, hold-down clamp sets, 3-jaw and 4-jaw vises, tool posts, collet sets and much more. See Sherline's tool and accessory website at [Sherline.com](#) for a complete list of accessories including illustrated instructions on their use.

Parts List		
NO. REQ.	PART NO.	DESCRIPTION
4	30561	10-32 T-Nut
4	35580	Angle Clamp
1	40080	Handwheel (P/N 41040, metric) (CNC versions only)
2*	40520	10-32 x 3/16" Cup Point Set Screw
4	40690	10-32 x 3/4" Socket Head Cap Screw
1	40740	10-32 x 7/8" Socket Head Cap Screw
1	40820	Gib Lock
1	40890	Leadscrew Nut, inch (P/N 41890, metric)
1	44210	8" Leadscrew, inch (P/N 44220, metric)
1	50171	13" Leadscrew, inch (P/N 51171, metric)
1	50173	18" Leadscrew, inch (P/N 51773, metric)
1	50980	Gib
1	50120	Backlash Lock Star Gear
1	50210	Button Head Socket Screw
1	50130	Backlash Lock Nut, inch (P/N 51130, metric)
1	65501	Base
1	65502	Table Lock
1	67018	2" Industrial Handwheel (Inch)
1	67118	2" Industrial Handwheel (Metric)
1	67019	Thrust Collar
1	67036	8" Slide Table
1	67050	13" Slide Table
1	54182	18" Slide Table
4	67100	8-32 x 3/8" Socket Head Cap Screw
1	67101	CNC Mount
1	67105	CNC Coupler
1	67106	Preload Nut, inch (P/N 67108, metric)
2	67111	8-32 x 7/8" Socket Head Cap Screw
1	67115	5-40 x 1" Socket Head Cap Screw
2	67120	Ball Bearing W/ Flange

* CNC versions include an extra set screw for the coupler. See exploded view on next page for location of each part.

Exploded View

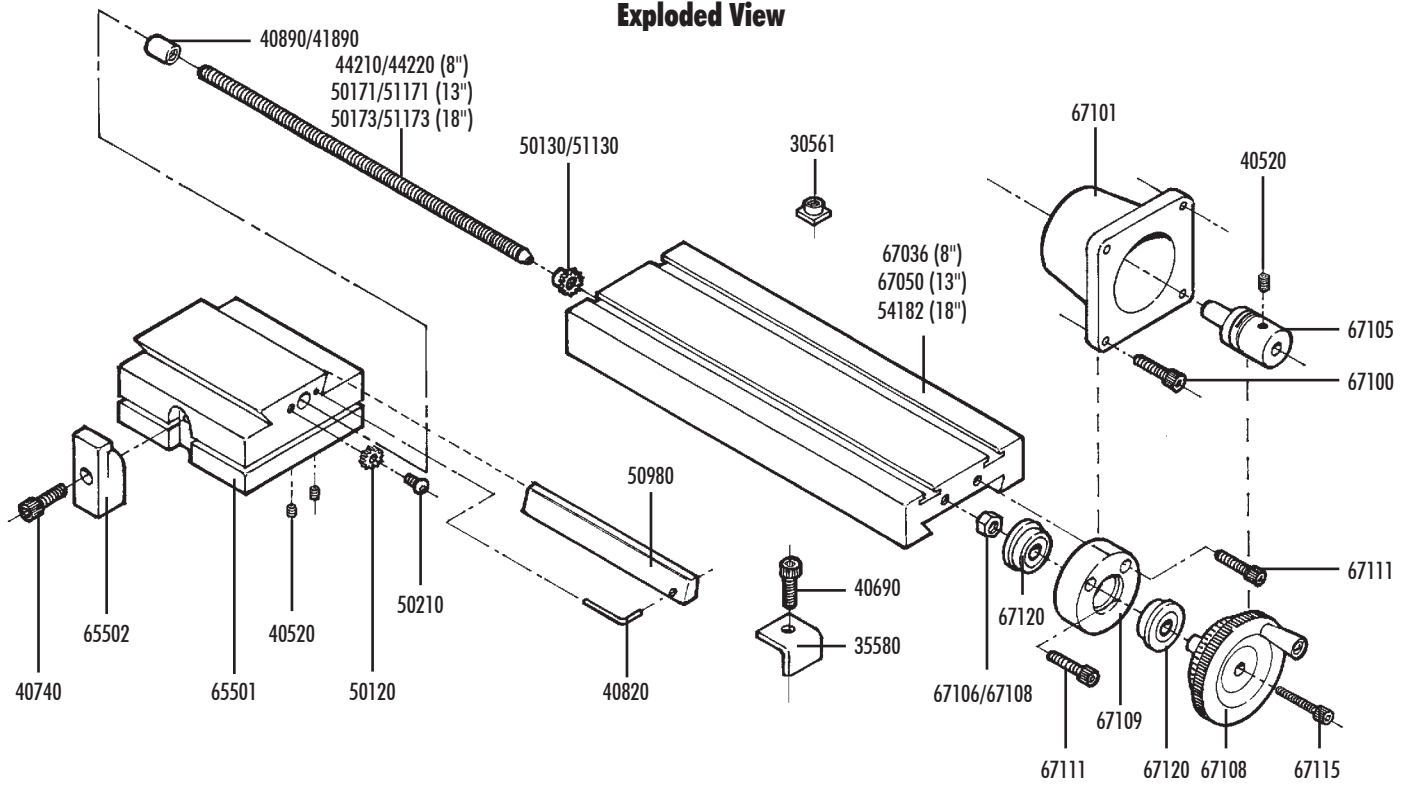

NOTE: Exploded view shows 8" table and both manual and CNC versions. Models with 13" and 18" tables look similar except for length of table. Either industrial handwheel or stepper motor mount are included with a given table, but not both. CNC versions include a standard Sherline handwheel (not shown) for mounting to dual-shaft stepper motor to provide manual control.