

Motor Detail

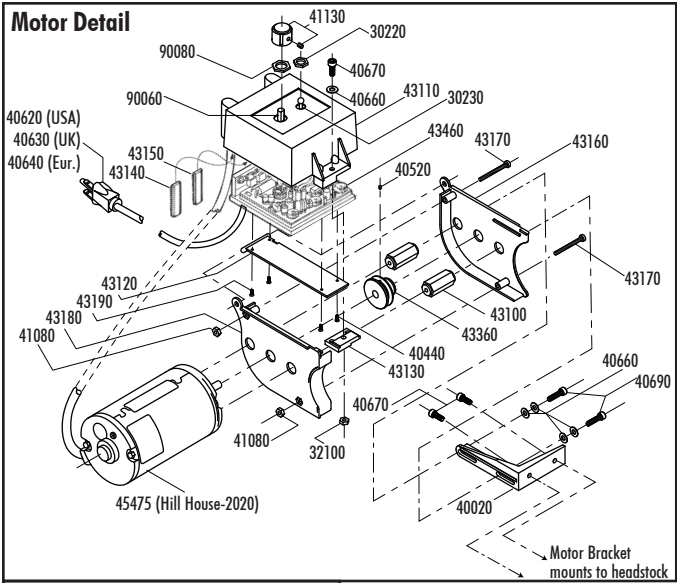

Chucker Saddle Oiler Detail

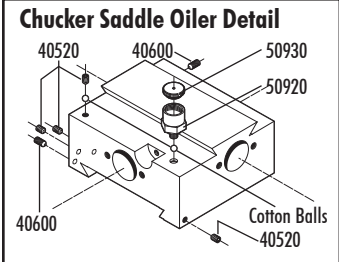

Ball Screw Coupling prior to 12/1/18

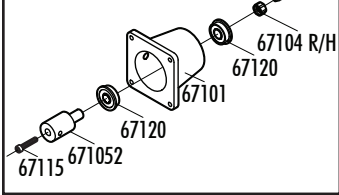

Sherline 6600 CNC Chucker Lathe
Exploded View and Part Numbers

