

Sherline 6840 CNC-Ready Ball Screw Lathe w/Limit Switches

NOTE: Where different, Inch part number is given first, followed by Metric part number.

Exploded View and Part Numbers

Optional Hard-Stop Kit Detail

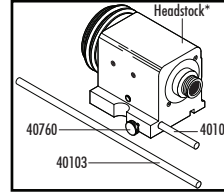

HARD-STOP KIT P/N 40116
 10-32 x 5/8" thumbscrew—40760
 4" hard-stop rod—40102
 8" hard-stop rod—40103
 * Headstock not included

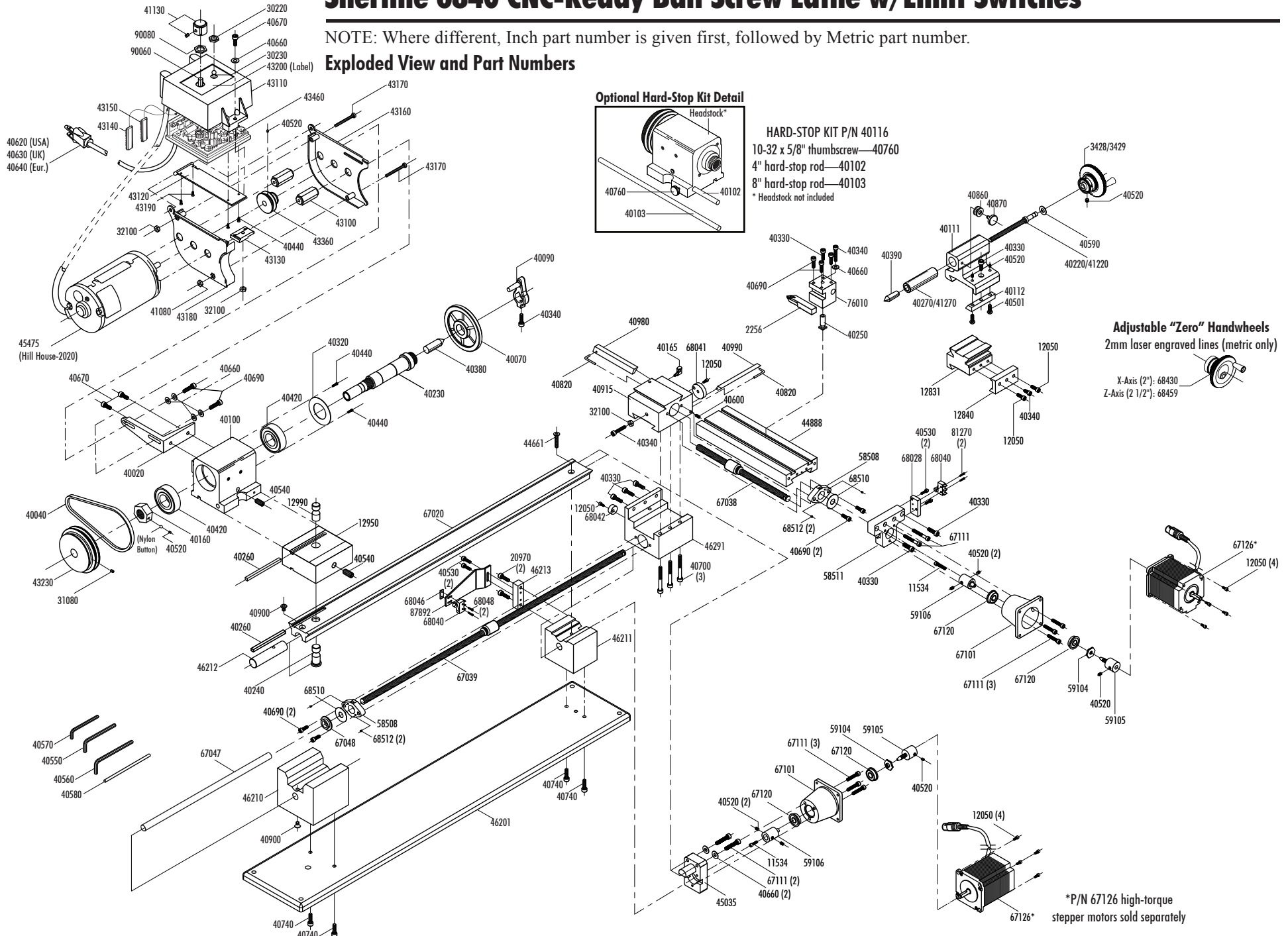

Adjustable "Zero" Handwheels 2mm laser engraved lines (metric only)

X-Axis (2"): 68430
 Z-Axis (2 1/2"): 68459

P/N 67126 high-torque stepper motors sold separately