



(P/N 6517 shown)



PRODUCT DESCRIPTION

6517—Headstock (dovetailed base) w/ 3/4-16 external, #1 Morse internal Spindle, DC motor, and speed control

6518—Headstock (dovetailed base) w/ ER-16 Spindle, DC motor and speed control (ER-16 collet not included)

Industrial Headstock with Dovetail Base with DC Motor and Speed Control

P/N 6517 and 6518

Spindle Precautions

It is important to realize that this spindle should be considered light duty. To make the spindle versatile, the spindle nose includes both a 3/4-16 external thread and a #1 Morse internal taper. A .405" (10 mm) through hole allows long, unsupported stock to be passed through the spindle. This design provides a lot of versatility, but was not intended for long or out-of-balance parts to be rotated at high RPM. It is up to the end user to determine if the spindle and the setup are adequate and safe for the job being attempted.

The spindle is equipped with a dust cap, but it is not totally sealed. The presence of dust from grinding operations can shorten bearing life considerably. It is also not designed to be operated in a coolant bath. The spindle shaft, motor and speed control should be shielded from coolant spray.

Introduction

This headstock has a dovetailed base that is designed to fit Sherline Industrial slides that utilize a dovetailed steel bed. It can be used in either a vertical or horizontal orientation.

The Sherline headstock, motor and speed control unit was developed based on components used in the Sherline lathe and milling machine. It features two 20 mm, class 5, lifetime lubricated ball bearings with an adjustable preload nut. The preload is adjusted at the factory to .0002" (.005mm) of endplay. This is controlled by the outer races of the bearings being held apart by the headstock case and the inner races being pulled together by the preload nut. This is appropriate for extended running at speeds in the range of 4000 RPM or less.

Optional Nickel/Teflon Spindles

Most of our spindles are available with a Nickel/Teflon plating as a rustproof option for an additional cost. You can select the option to add the Nickel/Teflon plating to your spindle order.

Adjusting the Preload

To reduce the preload adjustment, remove the spindle pulley, loosen the set screw in the preload nut and back the preload nut off four degrees of rotation (counterclockwise). The bearings are lightly pressed into the case, so the inner race

will not move without a sharp tap with a plastic mallet to the end of the spindle where the pulley was attached. When adjusted, retighten the set screw and reinstall the pulley.

If you find your bearings are set too loose, you may want to take up on the endplay. You can check them with an indicator or by spinning the spindle without the drive belt engaged. If the spindle spins freely with a chuck or faceplate on it, the spindle is too loose for normal work. Adjust the preload nut until the spindle turns approximately one and a half revolutions when spun by hand.

Accessories Available

Sherline manufactures a complete line of accessories for the headstock, including 3-jaw and 4-jaw chucks, drill chucks, collets, and special tool holders. These accessories will fit the 3/4-16 external spindle thread or the #1 Morse internal taper. See our tools and accessories website at Sherline.com, or call for a catalog.

Purchasing ER-16 Collets

ER-16 collets and collet nuts are available from major tool suppliers including the following:

- Manhattan Supply Co. (MSC)—(800) 645-7270
- McMaster-Carr—(562) 692-5911
- Travers Tool Co.—(800) 221-0270

Specifications

- Length of headstock base and gib: 3.5" (88.9 mm)
- Length of headstock case (at top): 3.00" (76.3 mm)
- Spindle centerline height above bed: 2.184" (55.47 mm)
- Hole through spindle: .405" (10 mm)
- Spindle nose thread (Model 6517): 3/4-16
- Spindle nose internal taper (Model 6517): #1 Morse
- Spindle nose thread and taper (Model 6518): ER-16
- Spindle bearings: (2) 20 mm, class 5, lifetime lubricated ball bearings with adjustable preload
- Spindle speed range: 70-2800 RPM

- Current input: 100VAC to 240VAC, 50 or 60 Hz.
- Overall weight: 10.5 lb. (4.8 kg.)

Mounting the Motor and Speed Control Unit to the Headstock

1. Remove the motor pulley from the motor shaft. Mount the inner belt guard to the motor using the two standoffs. Next, install the motor pulley to the motor shaft and tighten the set screw. The end of the pulley should be just about even with the end of the motor shaft, with the smaller pulley toward the end of the shaft.
2. Place the drive belt over the motor pulley.
3. Place the round post (A) on the speed control hinge plate in the hole on the inner belt guard (B). (See Figure 1.)

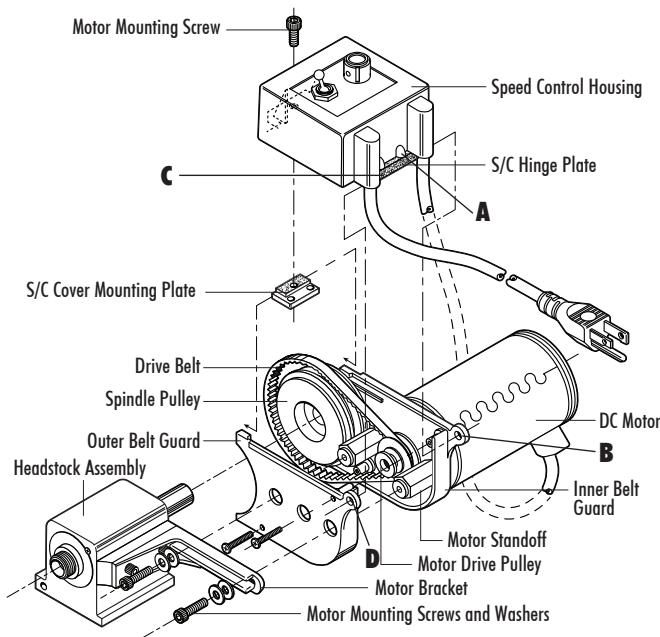

FIGURE 1—DC motor and speed control assembly (NOTE: Sherline machine tool headstock with flat base is shown, but motor assembly is the same on dovetailed headstock.)

4. Set the outer belt guard in place, locating the other post of the hinge plate (C) in its pivot hole (D). The motor standoff ends will register in holes in the outer belt guard. Make sure the drive belt is routed properly, then secure the cover with the two 1-3/8" pan head screws that go into nuts pressed into the back of the inner belt guard.
5. Attach the motor mounting bracket to the rear of the headstock with two 10-32 x 3/8" socket head screws. There is enough "play" in the mounting holes to allow you to ensure the motor is visually mounted parallel with the spindle axis. (Note: If an optional chip guard, P/N 4360) is to be mounted, its attachment screw replaces one of these mounting screws. It can be mounted at this time or after the headstock is in place. See instructions that come with the chip guard.)
6. Place the drive belt over the spindle pulley and insert two 10-32 x 3/4" socket head screws (with 2 washers on each) through the motor mount slot and into holes

in the ends of the motor standoffs. (These standoff ends should be exposed through locating holes in the outer belt guard.)

NOTE: The normal operating position for the drive belt is on the large diameter groove on the motor pulley and the small diameter groove on the spindle pulley. Use of the other (low RPM) position is discussed in the instructions on page 3.

7. Tighten the motor mount screws, tilt the speed control unit out of the way and check the alignment of the drive belt. It should be perpendicular to the drive pulleys. If it is not, loosen the set screw on the motor pulley and adjust it in or out on its shaft until the drive belt is running square with the motor.
8. Pull the desired tension into the drive belt by sliding the motor unit outward in the bracket slot. Tighten the mounting screws to hold the motor/speed control unit in place.

NOTE: Do not over-tension the drive belt. Just make sure it has enough tension to drive the spindle pulley without slipping under normal load. By not over-tightening the belt you will not only extend its life, but will also provide a margin of safety for belt slippage should a tool jam in a part or an accident occur. The belt must be a little tighter when used in the low speed range because small diameter pulleys are not as efficient.

9. Set the mounting plate into the top of the belt guard housing so it rests on the rails molded onto the inside surfaces of the housing. (The pressed-in nut faces down.) Slide the plate toward the outside (toward the spindle pulley) until it stops. The mounting plate was designed to be easily removable so it is out of the way when changing the drive belt position.
10. Rotate the speed control unit down into place and insert the single 10-32 x 3/8" socket head screw through the hole in the speed control housing and into the nut in the mounting plate. Tighten enough to hold it in place. Do not over-tighten.

NOTE: If you machine a lot of wood or brass, you may want to purchase and install a switch cover seal (P/N 3015) to keep the fine dust out of the power switch. The wood dust can gum up the switch causing intermittent operation. Brass dust can short out the switch or cause a risk of electric shock to the operator.

The Advantages of Sherline's DC Motor and Electronic Speed Control

The Sherline 90-volt DC motor is very smooth and powerful, particularly at low RPM. The specially designed electronics package also provides some unique advantages in addition to smooth speed control with a usable speed range of 70 to 2800 RPM. A special circuit compensates for load, helping to keep RPM constant. The machines can also be used on any current worldwide from 100 VAC to 240 VAC, 50 or 60 Hz without any further adjustment other than seeing that the proper wall plug is used. The control reads the incoming current and automatically adjusts to the proper settings.

Caution—Motor Is thermally Protected

Thermal protection means there is a built-in circuit breaker that will shut down the motor if it gets too hot. This keeps the motor from burning out. The breaker will automatically reset as soon as the motor cools and you can go back to work, but you should be aware of how it works and what to do if the machine suddenly shuts itself down. If your motor is shutting down from overheating on a regular basis, it means you are putting excessive load on the spindle or operating at too high an RPM for long periods. Slow your speed down, reduce your cut or feed rate, and you should have no further problems. When deciding on a workload for this component, keep in mind its size and power. Do not overload it by attempting jobs that should be done by a machine with more horsepower.

What to Do If the Motor Suddenly Shuts Down

If your thermal protection circuit shuts down the motor while work is in progress, immediately shut off the power switch and then back the tool out of the work. It should only take 10 seconds or less for the circuit breaker to reset, then you can turn the motor on and start the job again, this time putting a little less stress on the motor. If you leave the tool engaged in the part and the power on, when the circuit breaker kicks back on, the motor must start under load. This can be very hard on your motor.

NOTE: Remember—that the circuit breaker turns the speed control off, which turns off the motor. If power were to be applied to the speed control with the motor disconnected, it could damage the speed control.

Thermal protection is built into your motor to make sure it is not damaged due to overloading. Use good common sense when operating the motor and it will provide many years of trouble-free operation.

Operation of the Motor and Electronic Speed Control

The motor is supplied with an electronic speed control that produces a comprehensive range of speeds suitable for all operations. Special circuitry designed into the speed control automatically compensates for speed changes due to increased load. If the spindle RPM drops noticeably when cutting, you are taking too heavy a cut. The speed range of the spindle using the speed control is from 70 to 2800 RPM. This is achieved without the inconvenience of changing belt positions or gear ratios, as is often the case with other designs. A second belt position is offered as an additional feature to provide extra torque at low RPM for larger diameter parts should your job require it.

Proper Start-Up Procedure

To operate the motor, turn the speed control knob counterclockwise as far as it will go. Then turn the toggle switch to “ON” and select the desired speed by turning the speed control knob clockwise.

Motors Are Pre-Tested at the Factory

Your new motor should run smoothly the first time you use it, as it has been “run in” for about an hour before being shipped to you. Despite our secure packaging, there have

been cases where extremely rough handling by a shipper has damaged the magnets in the motor. If the motor does not run when plugged in, turn the motor by hand. If it does not turn smoothly, it may have been damaged in shipment. Call Sherline for instructions on making a damage claim with the shipper. The motor is not user-serviceable. Do not attempt to repair it yourself.

Two-Speed Pulley

The normal pulley position, which is placing the belt on the larger motor pulley and smaller headstock pulley, will suffice for most jobs. Moving the belt to the other position (smaller motor pulley, larger headstock pulley) will provide additional torque at lower RPM.

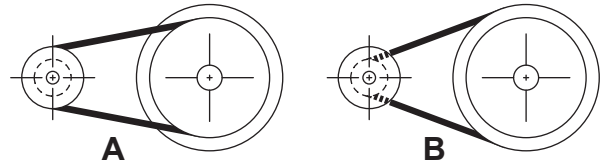

FIGURE 2—The two pulley positions. Position A is the conventional setting and offers a spindle speed range of 70 to 2800 RPM. Position B offers more torque at low RPM.

To change the pulley position, remove the speed control hold-down screw and pivot the speed control housing up out of the way. Remove the mounting plate from its position on the rails of the two halves of the belt guard housing. Loosen the two nuts that hold the motor to the motor mounting bracket and take the tension off the belt. With your finger, push the belt off the larger diameter groove of the pulley and into the smaller one. (Depending on which way you are changing it, this could be either the motor or spindle pulley.) Then move the belt to the larger diameter groove on the other pulley, and rotate the headstock by hand to get it to seat. Push the motor outward on the motor mounting bracket to put the proper tension on the belt, and retighten the two motor mounting screws. Now you can replace the mounting plate, pivot the speed control back down and refasten it. Moving the belt back to the other position is simply a reverse of the above procedure.

Mounting the Headstock to a Machine Slide

Lightly lubricate the dovetailed surfaces of the base or column material. Hook the angled edge of the dovetailed headstock base over the dovetail on the base or column. Attach the brass gib to the headstock using the three 10-32 x 5/8" socket head cap screws provided. Tighten each screw until the gib is seated evenly against the dovetail, and the headstock slides evenly on the base or bed with no side-to-side play. Tighten the three set screws in the side of the headstock against the gib adjustment screws to lock them in place. (Do not over-tighten or you can damage the threads of the attachment screws.)

Position the headstock at the end of its travel, as close to the handwheel (or stepper motor) end of the leadscrew as it will go. Rotate the leadscrew until the hole in the saddle nut aligns with the center hole in the saddle nut bracket on the headstock. Attach the saddle nut to the bracket using

the 10-32 x 5/8" socket head cap screw provided. Loosen the cap screw, bring each of the 10-32 x 1/4" flat point set screws on either side of it into light contact with the saddle nut and retighten the cap screw. If binding occurs when you move the headstock, readjust the two set screws until it moves smoothly.

Thank you,
 Sherline Products Inc.

Parts List, Headstock

NO. REQ.	PART NO.	DESCRIPTION
1	40160	Preload Nut
1	40230	Spindle (3/4-16/#1 Morse) (used on P/N 6517)
1	40320	Dust Cover
4	40330	10-32 x 5/8" SHCS
2	40410	Headstock Class 5 Bearings
2	40440	#2 X 1/4" Self-Tapping Phillips Head Screws
2	40600	10-32 X 1/4" Flat Point Set Screw
1	43230	2-Step V-Belt Pulley
1	65023	Spindle (ER-16) (used on P/N 6518)
1	65011	Headstock Case w/ Dovetailed Base
1	65012	Industrial Headstock Spacer
1	65013	Saddle Nut Attachment Plate
1	65014	Industrial Brass Gib
1	65026	ER-16 collet nut (used on P/N 6518)

Parts List, Motor And Speed Control

NO. REQ.	PART NO.	DESCRIPTION
1	30220	Toggle Switch Retaining Ring
1	30230	Toggle Switch
1	40020	Motor Bracket
2	40440	Self-Tapping Screw
1	40510	10-32 X 3/8" Socket Head Cap Screw
1	40520	10-32 X 3/16" Cup Point Set Screw
1	40620	Power Cord (USA)
5	40660	3/16" I.D. Washer
2	40690	10-32 X 3/4" Socket Head Cap Screw
3	41080	6-32 Hex Nut
1	41130	DC Speed Control Knob And Set Screw
2	43100	DC Motor Standoff
1	43110	DC Speed Control Case
1	43120	DC Speed Control Hinge
1	43130	DC Speed Control Cover Mounting Plate
1	43140	DC Speed Control Tab, Small
1	43150	DC Speed Control Tab, Large
1	43160	Belt Guard, Outer
2	43170	6-32 X 1-3/8" Pan Head Screw
1	43180	Belt Guard, Inner
2	43190	#2 X 1/4" Flat Head Sheet Metal Screw
1	43360	Stepped Motor Pulley
1	43450	DC Motor
1	43460	DC Speed Control Electronics
1	90060	DC Speed Control 5K Potentiometer
1	90080	3/8-32 Hex Nut

Exploded View and Part Numbers—Headstock, Motor and Speed Control

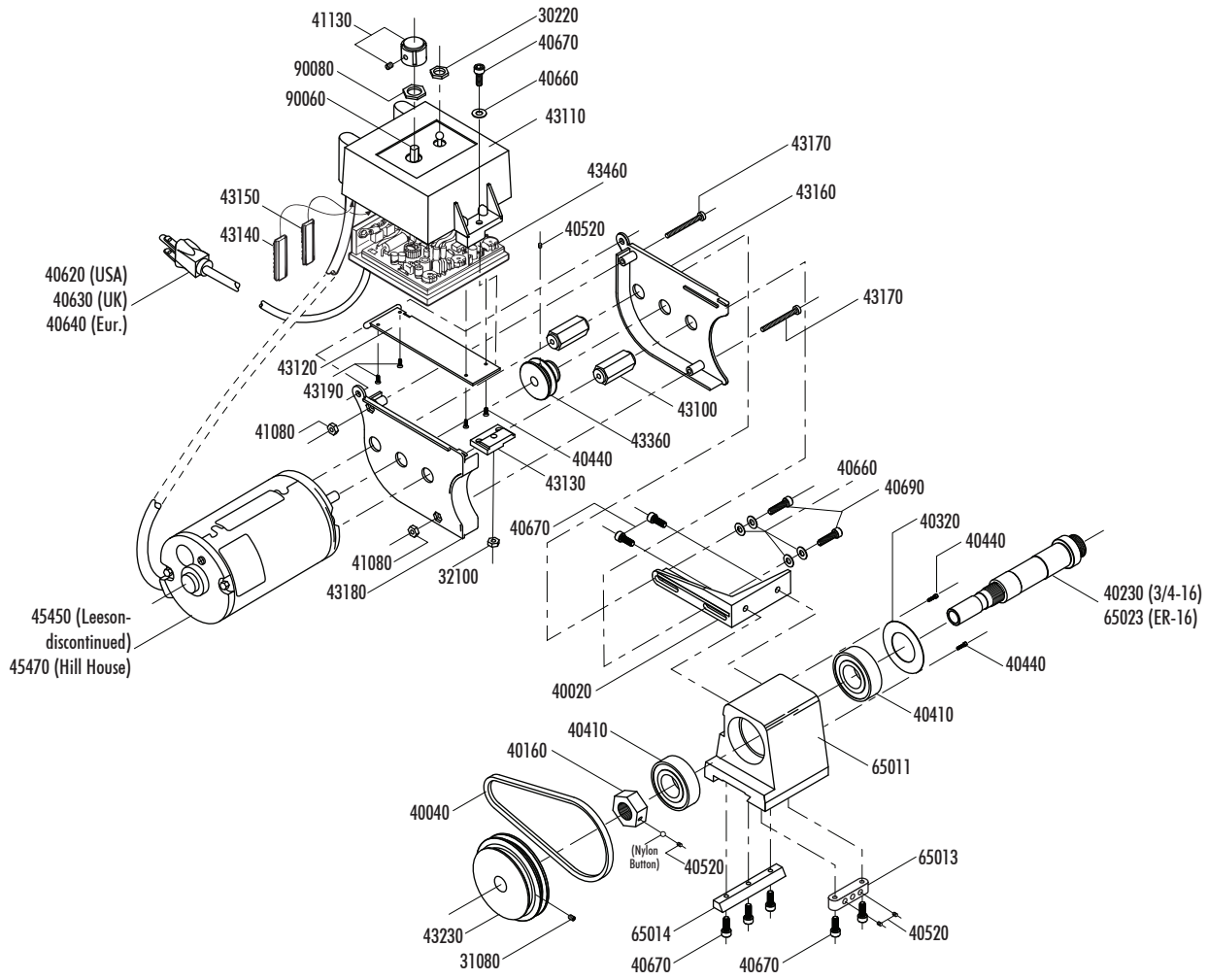

TAPERED DOVETAIL-BASE HEADSTOCK P/N 65011

